

Purchasing Dept  
Copy

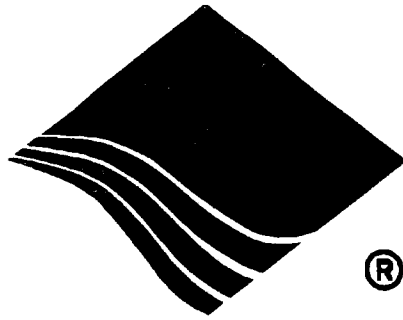

**HIGHLEAD**

**GC0398-1/GC0398-1-D**

**Heavy Duty Top And Bottom Feed  
(With Automatic Thread Trimmer)  
Lockstitch Sewing Machine**

**Instruction Manual  
Parts Catalog**

**SHANGHAI HUIGONG NO.3 SEWING MACHINE FACTORY**

From the library of: Superior Sewing Machine & Supply LLC



---

## CONTENTS

1. PRECAUTIONS BEFORE STARTING OPERATION .....	1
1) Safety precautions .....	1
2) Precautions before starting operation .....	1
3) Precautions for operation conditions .....	1
2. Specifications .....	1
3. Installing the belt.....	2
4. Adjustment of needle bar stop position.....	2
1) Adjustment of "UP" position .....	2
2) Adjustment of "DOWN" position .....	2
3) Confirm the stop operation then the plug (12 pins) coming from the machine head into the receptacle .....	2
5. Lubrication.....	3
6. Condition of oil lubrication.....	3
7. Adjustment of the hook lubrication.....	3
8. Adjustment of oil pump .....	3
9. Periodical cleaning .....	3
10. Installation of belt cover .....	4
11. How to wind the lower thread .....	4
12. How to attach a needle .....	4
13. How to route the upper thread .....	5
14. Adjustment of stitch length and reverse sewing.....	5
15. Adjusting the thread tension.....	6
16. Upper thread tension.....	6
17. Lower thread tension.....	6
18. Adjustment of presser pressure.....	6
19. Feed dog height.....	7
20. Adjustment of feed dog inclination.....	7
21. Presser bar lifter.....	7
22. Adjustment of walking foot and presser foot.....	7
1) Adjustment of alternating movement.....	7
2) To change the balance of the alternating movements between the walking foot and presser foot .....	8
3) Installing the feed regulator bracke .....	8
4) Feed pitch adjustment of walking foot .....	8
23. Adjustment of feed timing.....	9
24. Adjustment of thread trimmer mechanism.....	10

---

---

1) The thread trimmer mechanism illustrated as.....	10
2) Installing the thread trimmer solenoid unit .....	10
3) Adjustment of knife engagement .....	10
25. Needle, Thread and Material to be Sewn .....	11

# 1. PRECAUTIONS BEFORES STARING OPERATION

## 1) Safety precautions:

(1) When turning the power on, keep your hands and fingers away from the area around/under the needle and the area around the pulley.

(2) Power must be turned off when the machine is not in use, or when the operator leaves the seat.

(3) Power must be turned off when tilting the machine head, installing or removing the “V” belt, adjusting the machine, or when replacing.

(4) Avoid placing fingers, hairs, bars etc., near the pulley, “V” belt, bobbin winder pulley, or motor when the machine is in operation.

(5) Do not insert fingers into the thread take-up cover, under/around the needle, or pulley when the machine is in operation.

(6) If a belt cover, finger guard, eye guard are installed, do not operate the machine without these safety devices.

## 2) Precautions before starting operation:

(1) If the machine’s oil pan has an oil sump, never operate the machine before filling it.

(2) If the machine is lubricated by a drop oiler, never operate the machine before lubricating.

(3) When a new sewing machine is first turned on, verify the rotational direction of the pulley with the power on. (The pulley should rotate counterclockwise when viewed from the pulley)

(4) Verify the voltage and (single or three) phase with those given on the machine nameplate.

## 3) Precautions for operating conditions:

1) Avoid using the machine at abnormally high temperatures (35°C or higher) or low temperatures (5°C or lower) .

2) Avoid using the machine in dusty conditions.

## 2. Specifications:

Model		GC0398-1	GC0398-1-D
Specifications			
Material Weight		Heavy	
Max. Sewing Speed		2,000 rpm	
Stitch Length		0—10 mm	
Needle Bar Stroke		35.0 mm	
Thread Take-up Lever Stroke		72.0 mm	
Alternating Movement		2.0-5.0 mm	
Walking Foot Alternate Operating System		Dial	
Feed Dog Height		1.0 mm	
Needle		DP×17 14#-24#	
Presser Foot Stroke	By Hand	6.0 mm	
	By Knee	16.0 mm	
Lubrication System		Automatic	
Thread Trimmer		×	○
Touch Back		○	

### 3. Installing the belt (Fig.1):

- 1) Use a V-belt for sewing machine use, type M.
- 2) To adjust the belt tension, change the motor height by turning the tension adjust nuts so that the belt sinks about 15mm when depressed by hand at the center of the belt span.

If the tension is too low, the speed may not be consistent in the low or medium range, or the needle may not stop in the proper position. If the tension is too high, the motor bearings will deteriorate more rapidly.

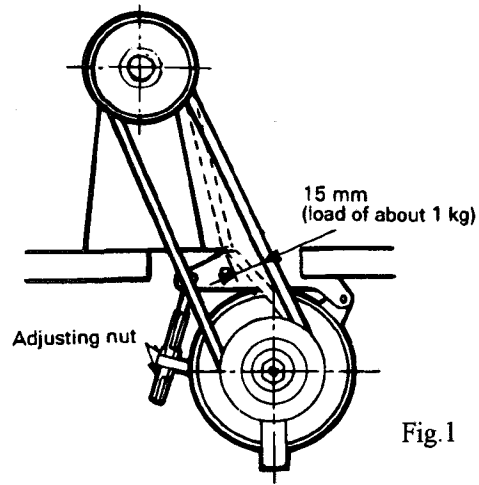

### 4. Adjustment of needle bar stop position (Fig2, Fig3, Fig4):

#### 1) Adjustment of "UP" position

When the pedal is kicked down by heel to cut the thread, the machine stops in the "UP" position. If the marks deviate more than 3mm, adjust as follows:

- (1) Disconnect the plug (12 pins) from the control panel;
- (2) Run the machine and stop in the "UP" position;
- (3) While holding the pulley, insert the adjusting tool into the two holes marked "A", then rotate the pulley.

#### 2) Adjustment of "DOWN" position

When the pedal is returned to the neutral position, the machine stops in the "DOWN" position. If the marks deviate more than 3mm, adjust as follows:

- (1) Disconnect the plug (12 pins) from the control panel;
- (2) Run the machine and stop in the "DOWN" position;
- (3) While holding the pulley, insert the adjusting tool into the two holes marked "B", then rotate the pulley.

3) Confirm the stop operation then the plug (12 pins) coming from the machine head into the receptacle.

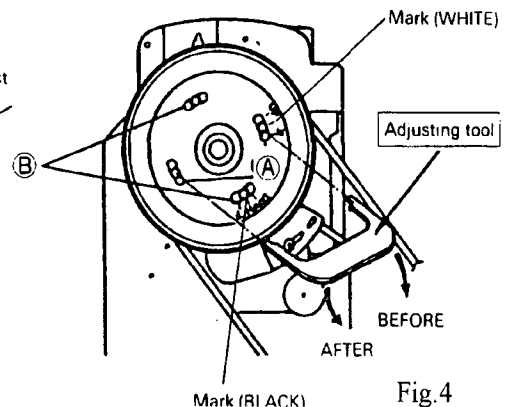
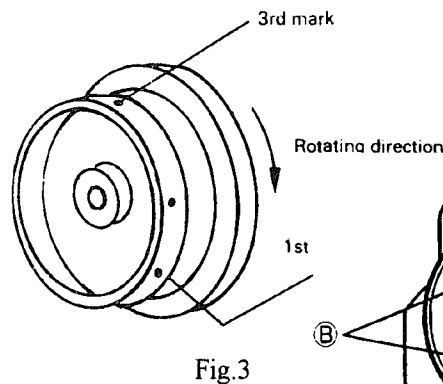
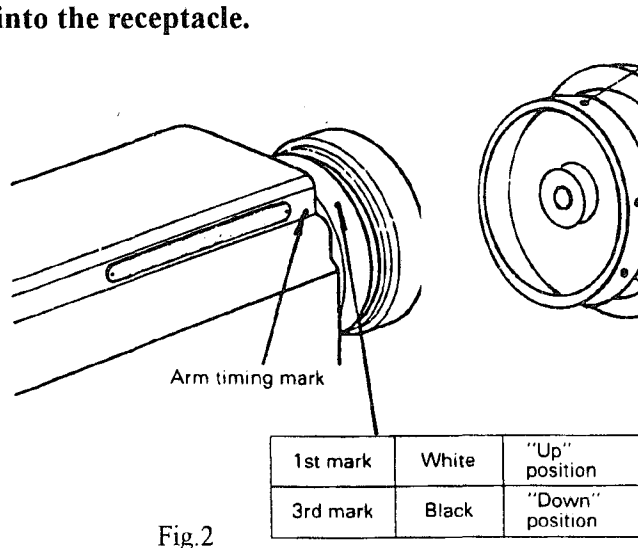

## 5. Lubrication (Fig.5):

Pour oil up to position "A" of the oil tank.

During operation, check the oil level periodically, and in cases where the oil level is below position "B", replenish the oil supply up to position "A".

Use white spindle oil.

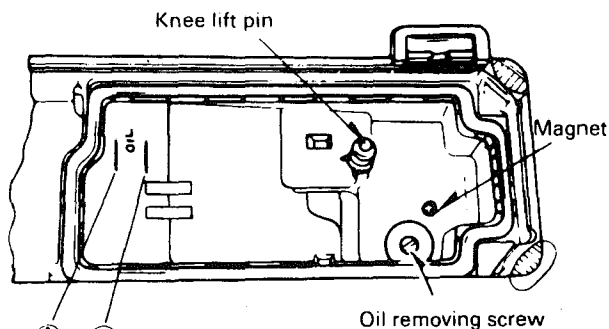

Fig.5

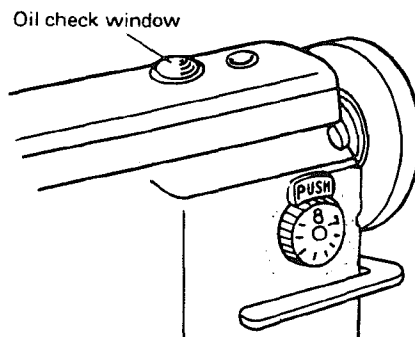

Fig.6

## 6. Condition of oil lubrication (Fig.6):

While operating the machine, check the condition of oil lubrication through the oil check window.

## 7. Adjustment of the hook lubrication (Fig.7):

Adjustment can be done by turning screw "A".

(1) When the screw has been fully tightened ... Maximum

(2) When the screw has been fully loosened ... Maximum

**Note:** After adjustment of this screw, the machine should be operated for at least 30 seconds, then check the oil mist from the hook.

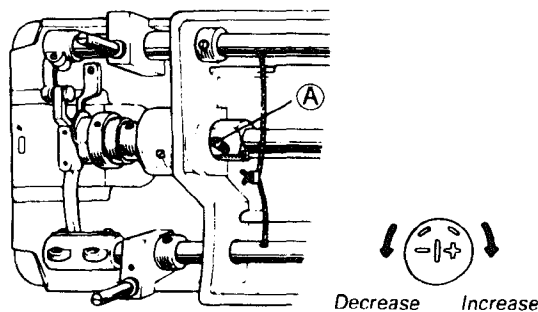

Fig.7

## 8. Adjustment of oil pump (Fig. 8):

The standard adjustment is as follows:

The adjusting plate keeps the bypass hole fully closed. To decrease splashing, open the bypass hole appropriately.

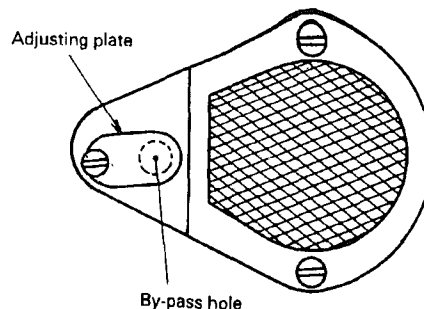

Fig.8

## 9. Periodical cleaning (Fig.9, Fig.10, Fig.11):

Clean the feed dog, hook and oil pump periodically.

Maintenance of motor: Remove dust from the motor filter every one or two months.

Control box: Remove dust from the connector.

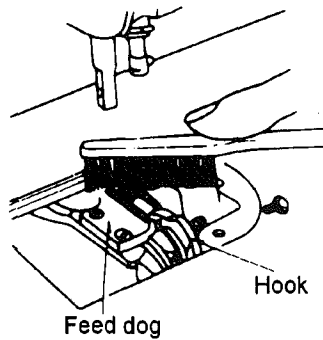

Fig. 9

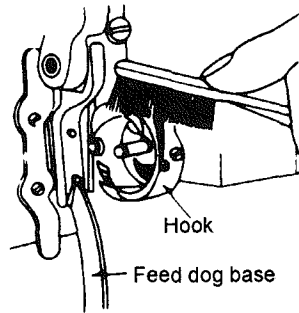

Fig. 10

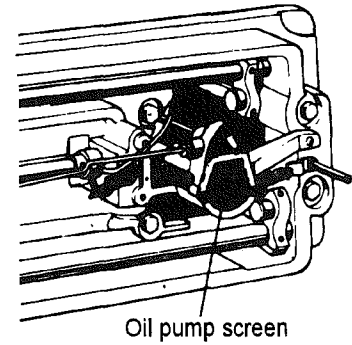

Fig. 11

## 10. Installation of belt cover:

Be sure to install the belt cover for safety.

## 11. How to wind the lower thread (Fig.12):

Strength of winding: Particularly in the case of nylon or polyester thread, wind the bobbin loosely.

Uneven winding: If the bobbin is wound unevenly, slide the thread guide toward the less wound portion of bobbin.

Winding amount: When the bobbin is wound excessively, loosen the adjusting screw. When the bobbin is wound insufficiently, tighten the adjusting screw.

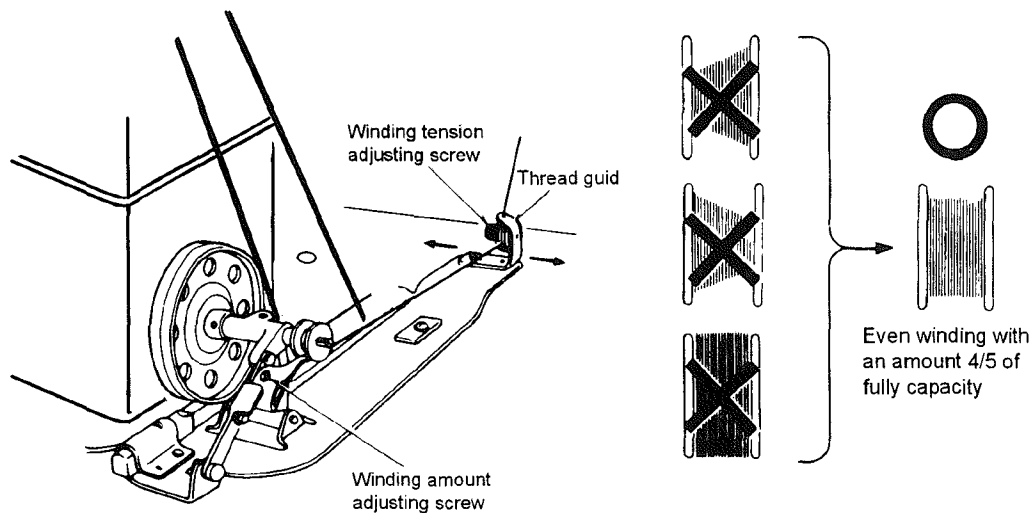

Fig. 12

## 12. How to attach a needle (Fig.13):

Note: Before attach the needle, be sure to turn the power switch off.

Note: If thread snapping occurs during reverse sewing with polyester, it may be avoided by fitting the needle with the long groove shifted to the front side. Normally, avoid fitting the needle with the groove facing backward.



Insert the needle until it bottoms, and tighten the screw keeping the long groove in the needle facing to the left.

Insufficient insertion

Wrong direction

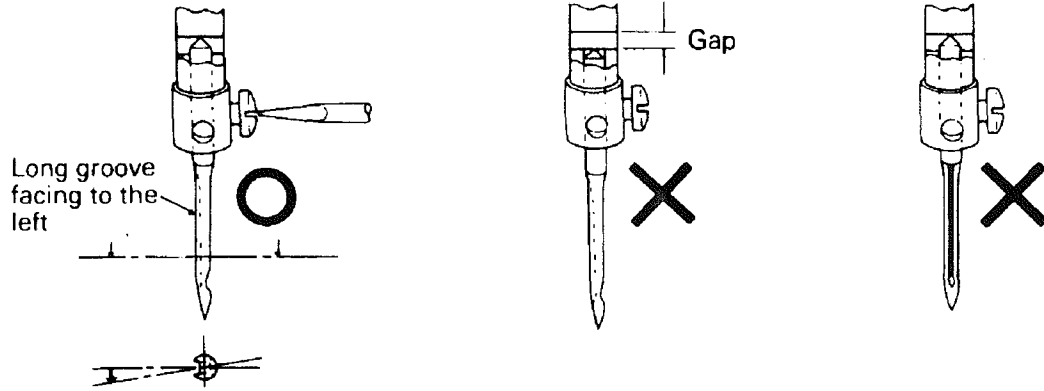

Fig.13

### 13. How to route the upper thread (Fig.14):

Raise the thread take-up lever to its highest possible position, and route the upper thread in the order illustrated below.

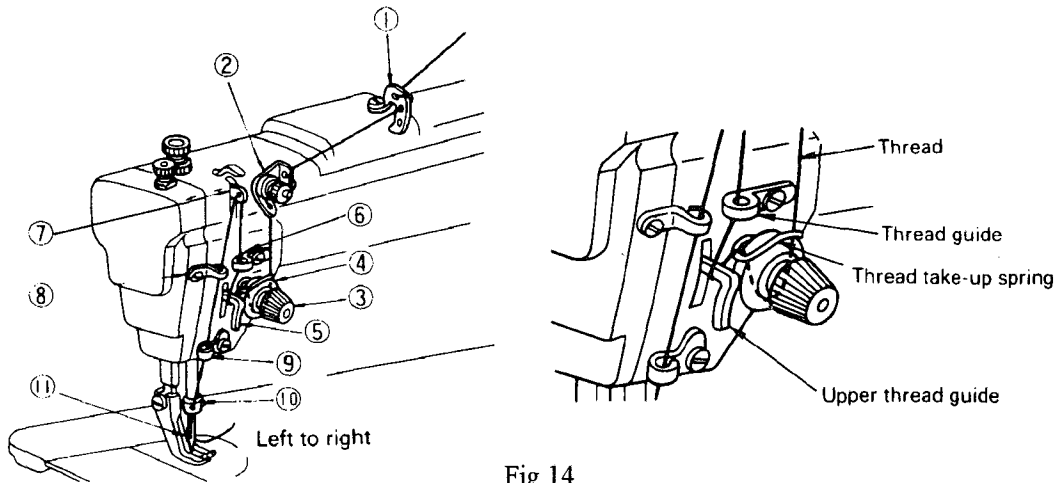

Fig.14

### 14. Adjustment of stitch length and reverse sewing (Fig.15):

- 1) To change the stitch length, rotate the stitch length adjusting dial while pressing the "push" lever.
- 2) Pressing the stitch length adjusting lever for reverse stitching.

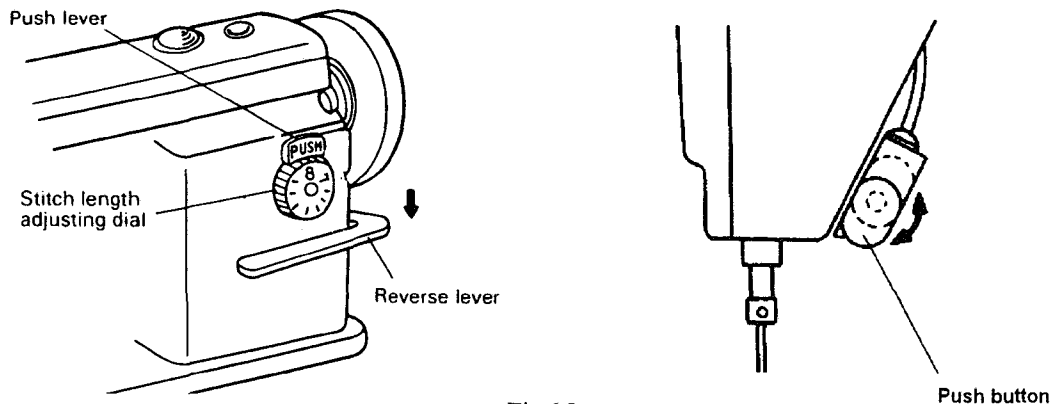

Fig.15

## 15. Adjusting the thread tension (Fig. 16):

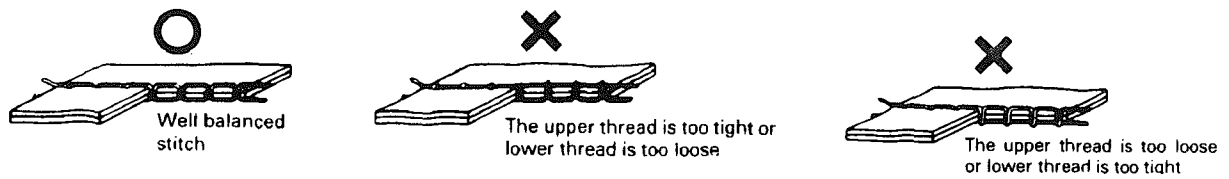

Fig.16

## 16. Upper thread tension (Fig.17):

- 1) The upper thread can be adjusted based on the lower thread tension.
- 2) Adjustment can be done by rotating the thread tension nut.

For special fabric sewing with special thread, the desired tension can be obtained by adjusting the strength and operating range of thread take-up spring.

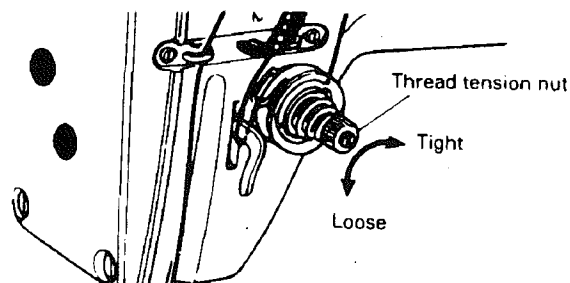

Fig.17

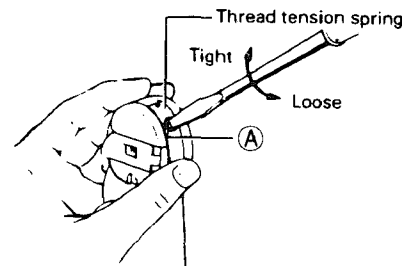

Fig.18

## 17. Lower thread tension (Fig.18):

Lower thread tension can be adjusted by rotating screw "A".

## 18. Adjustment of presser pressure (Fig.19):

- 1) Pressure should be adjusted according to the material to be sewn.
- 2) Pressure on both the walking foot and the presser foot can be adjusted.
- 3) Sewing pressure should be adjusted to the minimum required strength.

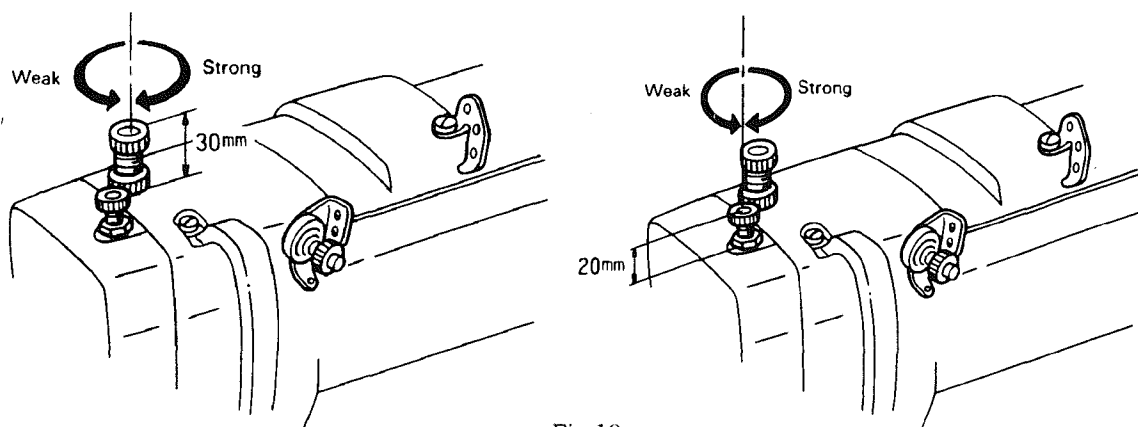

Fig.19

## 19. Feed dog height (Fig.20):

- 1) Feed dog should be 1.0mm higher than the throat plate.
- 2) To adjust the dog height as follows:
  - (1) Loosen the screw "A", move the feed bar upward and downward.
  - (2) When adjustment is completed, tighten the screw "A".

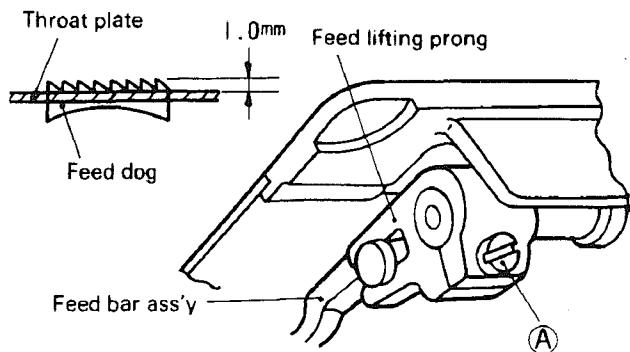

Fig.20

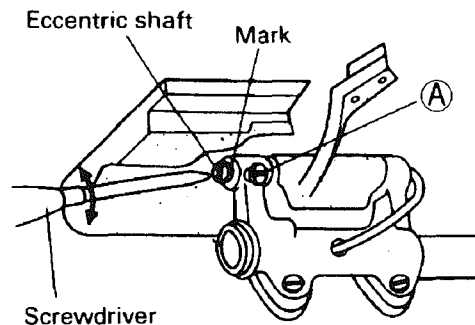

Fig.21

## 20. Adjustment of feed dog inclination (Fig.21):

If necessary, adjust the inclination according to the material to be sewn as follows:

Position of mark on the eccentric shaft	Feed dog
Horizontal	Standard
Up	Front up (MAX.)
Down	Front down (MAX.)

- 1) Loosen the screw "A".
- 2) Rotate the eccentric shaft clockwise or counterclockwise with screw driver.
- 3) Tighten the screw "A".

## 21. Presser bar lifter (Fig.22):

Rotate the presser bar lifter in the direction of the arrow. This raises the presser foot.

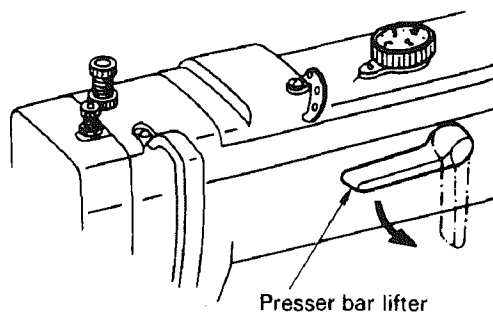

Fig.22

## 22. Adjustment of walking foot and presser foot:

### 1) Adjustment of alternating movement (Fig23):

- (1) The alternating movement on the walking foot and presser foot can be adjusted by using adjusting dial located on the top cover.
- (2) Face the desired number printed on the dial to the matching mark located on the top cover. The number printed on the dial represents the possible protrusion of the walking foot and presser foot from the throat plate when the alternating movements on these are evenly set.

(3) The alternating movements can be readjusted up to 2.0-5.0mm.

**2) To change the balance of the alternating movements between the walking foot and presser foot (Fig.24):**

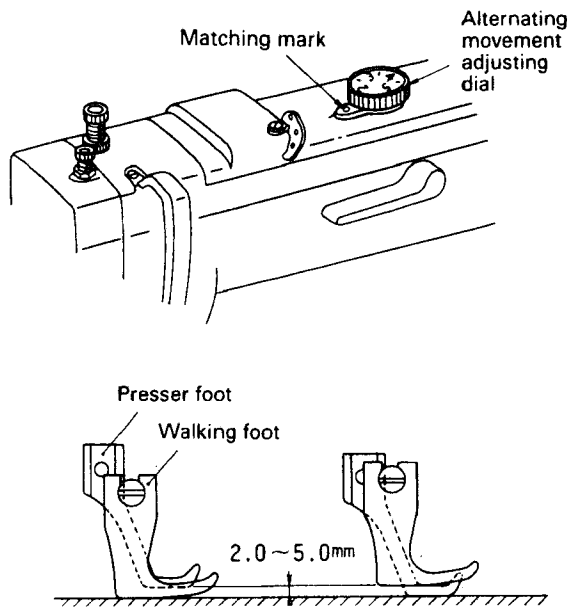

Fig.23

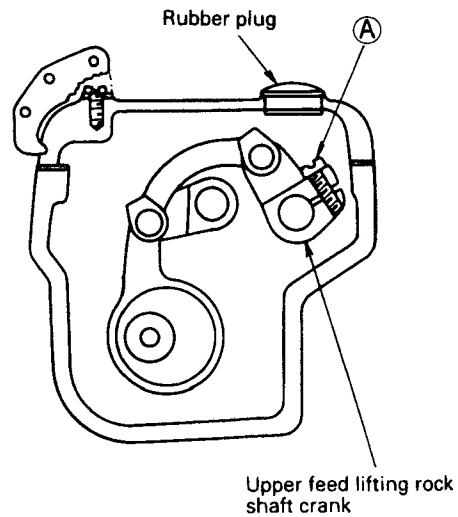

Fig.24

(1) To increase the rise of the walking foot and decrease the rise of the presser foot:

- ① Remove the rubber plug of top cover.
- ② Rotate the pulley until the presser foot is slightly raised from the throat plate.
- ③ Loosen screw "A" (on the right side)
- ④ The built-in spring pulls down the presser foot until it makes contact with the throat plate. Tighten the screw "A".
- ⑤ After this adjustment, the protrusion of the presser foot has been decreased by a set distance. And the vertical motion of the walking foot has been increased by the same distance.

(2) As a contrary case (1), to decrease the rise of the walking foot and increase the rise of presser foot as follows:

First, rotate the pulley until the walking foot is slightly raised from the throat plate. Next, loosen screw "A". Finally, tighten screw "A". This decreases the rise of the walking foot.

**3) Installing the feed regulator bracke (Fig.25):**

**Note:** If the feed regulator bracket is poorly positioned, the resultant alternating movements may be too short or long, causing defective machine operation.

(1) Set the clearance between special screw "A" located on the regulator stud and the side wall of the machine arm to 27.5mm as Fig.25.

(2) With the feed regulator stud held as explained in step (1) above, adjust the feed regulator bracket. This adjustment should insure a clearance of 12mm between the periphery of pin "B" located on the feed regulator bracket and the top cover mounting face located on the arm. Tighten screw "C".

**4) Feed pitch adjustment of walking foot (Fig.26):**

The ratio of the upper feed amount (of the walking foot) to the lower feed amount (of the feed dog) has been adjusted to 1:1. However, the walking foot feeding amount can be increased or decreased depending on the operating conditions.

Loosen the nut located on the upper feed rock shaft crank (left), and shift to adjust the position of the pivot bracket upward or downward.

Upper position → Feed pitch → Small

Lower position → Feed pitch → Large

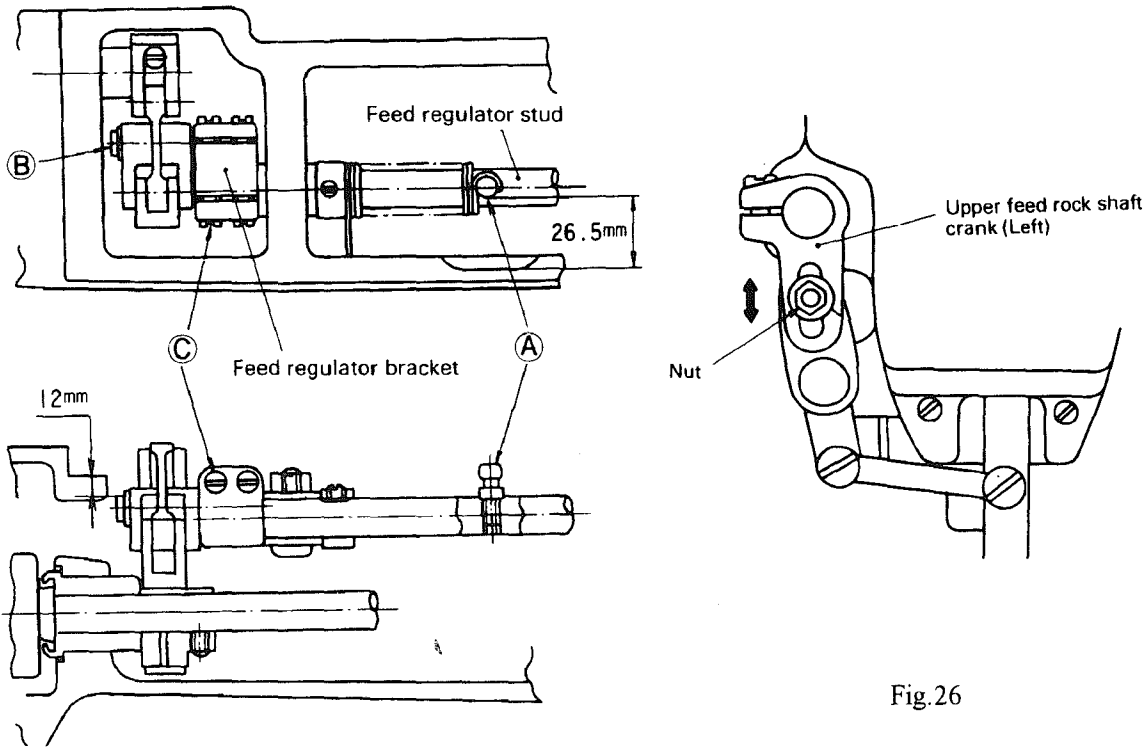

Fig.25

Fig.26

### 23. Adjustment of feed timing (Fig.27):

- 1) The standard position of the eccentric feed cam and eccentric feed lifting cam are illustrated to Fig.27
- 2) Open the top cover, properly slide the eccentric ring to adjust the position.
- 3) The eccentric feed cam can also be adjusted by removing the rubber plug located on the top cover. In the latter case, however, the built-in bevel gear is concealed; care should be taken when adjusting.

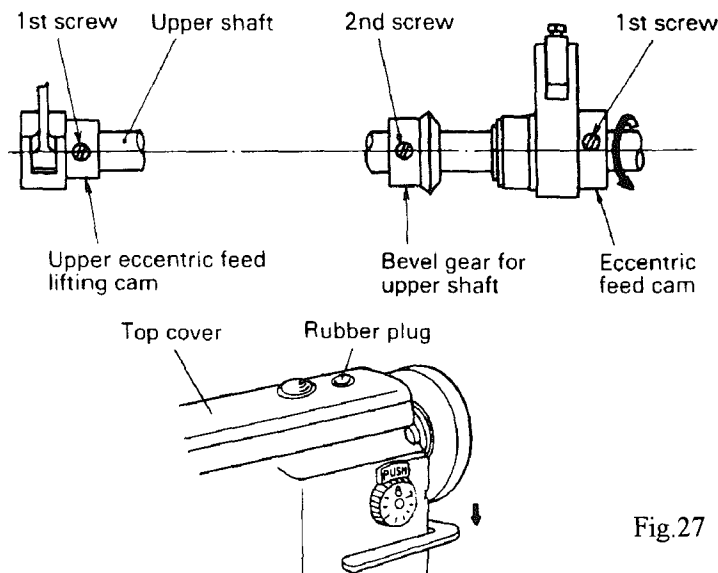

Fig.27

## 24. Adjustment of thread trimmer mechanism:

### 1) The thread trimmer mechanism illustrated as Fig.28

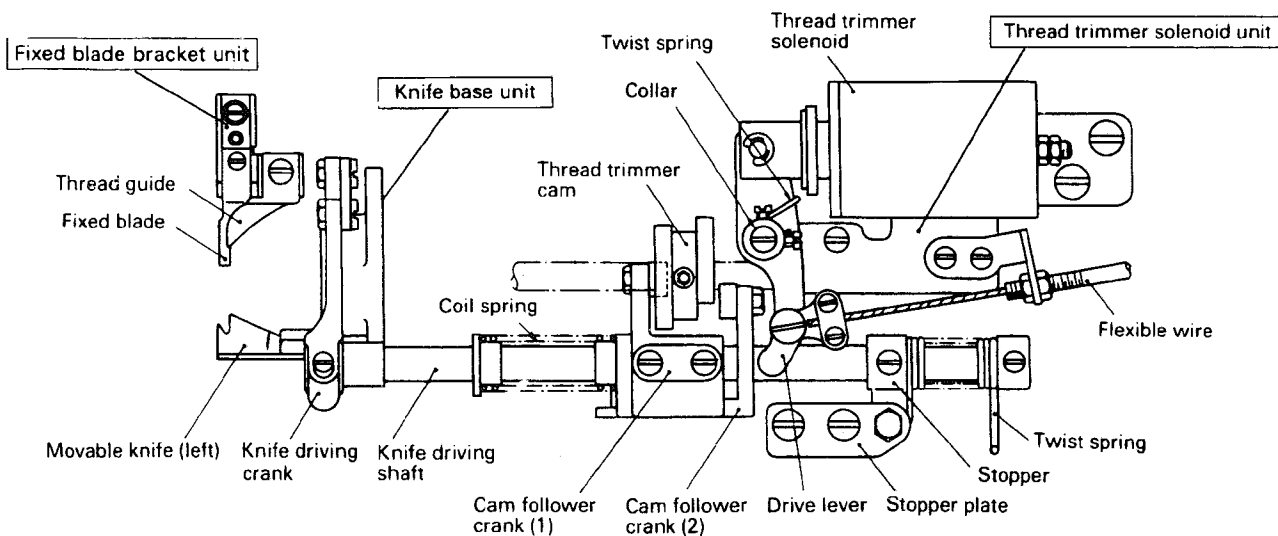

Fig.28

### 2) Installing the thread trimmer solenoid unit Fig.29:

#### (1) Operation stroke of the thread trimmer solenoid:

- Standard operation stroke is 6.0mm.
- This stroke can be adjusted by using nut "A".

nut "A".

#### (2) Installing the unit:

- The unit can be mounted by using screws "B" and "C".
- Clearance of 1.0mm must be insured between the driving lever and cam follower crank 2 with stopper nut "A" made contact with solenoid.
- In such a situation, activating the solenoid should create a clearance of 0.5mm between cam follower crank 1 and 2. This situation is standard. To meet this standard, slide the solenoid mounting bracket in the direction of the arrow as illustrated, if adjustment is needed.

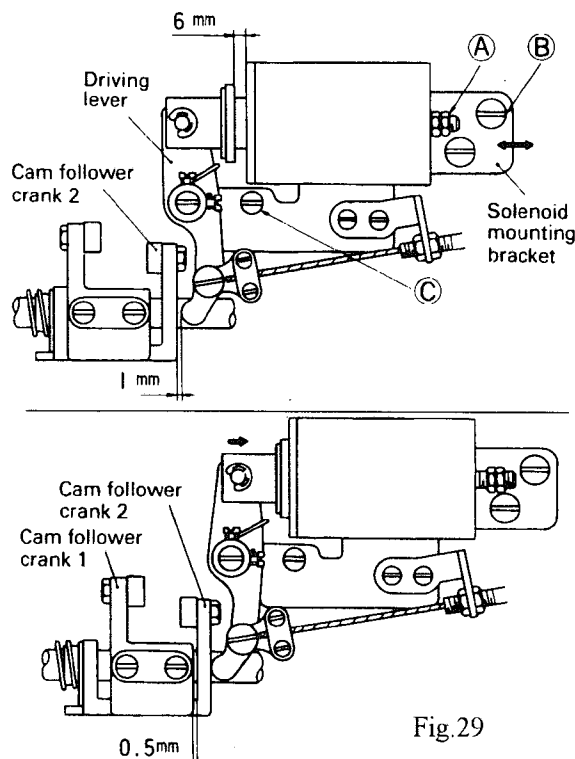

Fig.29

### 3) Adjustment of knife engagement (Fig.30):

#### (1) Position of movable knife (left) and fixed blade:

See the Fig.30, the standard distances from the needle center are 7.5mm and 5mm from the movable knife (left) and fixed blade respectively.

### (2) Adjustment of knife engagement:

With the solenoid activated, turn on the machine. This rotates the thread trimming cam which rotates the movable knife (left). When the movable knife (left) has moved to its farthest distance, the standard engagement of the blade is 1.5mm-2.0mm. The engagement can be adjusted by properly mounting the drive arm.

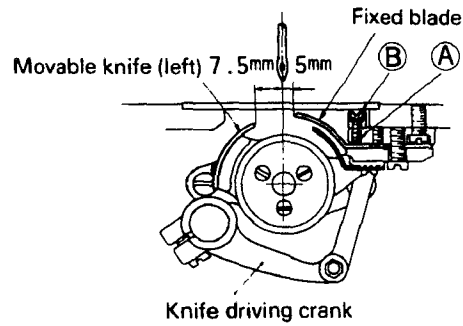

### (3) Adjustment of knife engagement pressure:

a. If a thread is poorly cut, particularly when it is thick, slightly increase the engaging pressure. This should solve the problem.

b. The engaging pressure can be adjusted in this way:

Loosen lock nut "B" and adjust it by using adjusting screw "A".

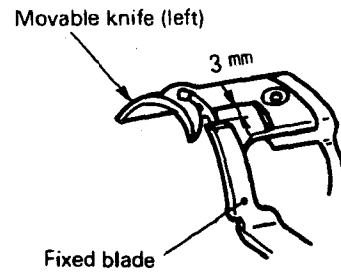
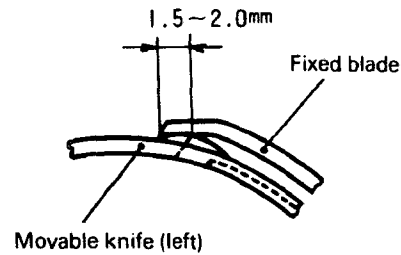
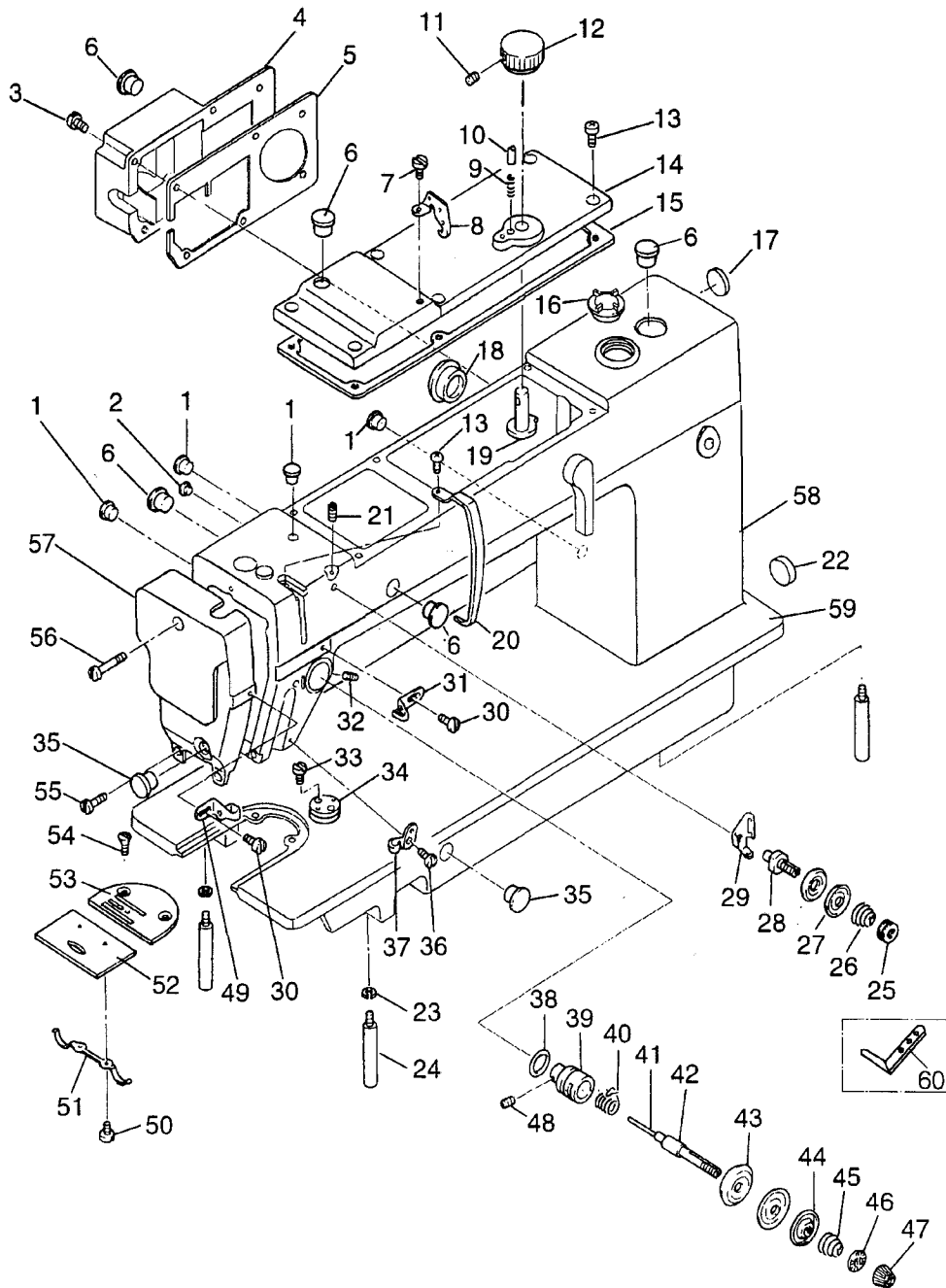

Fig.30

## 25. Needle, Thread and Material to be Sewn

Needle Size	Thread No.	Material
No. 14	No. 60 - No. 65	Cotton, Woolen
No. 16	No. 30 - No. 50	Muslin, Woolen, Tarpaulin, Thin Leather
No. 22		Medium Leather, Canvas

# A.ARM BED AND ITS ACCESSORIES





## A.ARM BED AND ITS ACCESSORIES

Fig. No.	Part No.	Description	1	1 D	Remarks
A01	HA300B2090	Rubber plug	4	4	(φ8.8)
A02	HA300B2110	Rubber plug	1	1	(φ5.7)
A03	HA300B2160	Screw	6	6	SM11/64(40)×9
A04	H6512B8001	Arm side cover	1	1	
A05	H6513B8001	Gasket for arm side cover	1	1	
A06	HA307B0673	Rubber plug	3	5	(φ19)
A07	HA700F2100	Screw	1	1	SM11/64(40)×7
A08	H6017B8001	Thread guide	1	1	
A09	H6022B8001	Coil spring for upper feed lifting	1	1	
A10	H6023B8001	Stopper pin for upper feed lifting	1	1	
A11	H431040060	Set screw	2	2	GB/T80 M4×6
A12	H6024B7101	Dial for upper feed lifting	1	1	
A13	HA300C2030	Screw	7	7	SM11/64(40)×8
A14	H6515B8001	Top cover	1	1	
A15	H6516B8001	Gasket for top cover	1	1	
A16	H1210B0067	Oil check window	1	1	
A17	H6030B8001	Rubber plug	1	1	(φ22)
A18	H6032B8001	Rubber plug	1	1	(φ26)
A19	H6518B8001	Upper feed lifting regulator cam	1	1	
A20	HA600C2020	Thread take-up cover	1	1	
A21	HA100B2110	Screw	1	1	SM11/64(40)×5.5
A22	HA300B2100	Rubber plug	1	1	(φ27)
A23	H005008060	Spring washer	2	2	GB/T93 6
A24	HA100B2220	Leg	3	3	
A25	HA710B0671	Pre tension adjusting nut		1	
A26	HA710B0672	Thread tension spring		1	
A27	HA112B0693	Thread tension disc		2	
A28	HA710B0673	Thread tension stud		1	
A29	HA710B0674	Thread guide		1	
A30	HA106B0676	Screw	2	2	SM9/64(40)×6
A31	HA600B2050	Thread guide	1	1	
A32	HA300B2080	Screw	1	1	SM15/64(28)
A33	HA300B2130	Screw	2	2	SM11/64(40)×5.5
A34	HA300B2140	Cloth guide plate	1	1	
A35	HA307B0674	Rubber plug	2	4	(φ11.8)
A36	HA500C2070	Screw	1	1	SM9/64(40)×5
A37	HA500C2060	Thread guide	1	1	
A38	HA115B7011	O-ring	1	1	
A39	HA310B0703	Thread tension regulator bushing	1	1	
A40	HA505B0672	Thread take-up spring	1	1	
A41	HA115B0709	Thread releasing pin	1	1	
A42	HA115B0701	Thread tension stud	1	1	
A43	HA310B0705	Thread tension disc	2	2	

## A.ARM BED AND ITS ACCESSORIES

Fig. No.	Part No.	Description	1	1 D	Remarks
A44	HA310B0702	Thread tension releasing disc	1	1	
A45	HA505B0671	Thread tension spring	1	1	
A46	HA115B7010	Thumb nut revolution stopper	1	1	
A47	HA310B0701	Thumb nut	1	1	
A48	HA115B0708	Screw	1	1	SM9/64(40)×6
A49	HA607B0671	Thread guide	1	1	
A50	HA124B0713	Screw	2	2	
A51	HA124B0712	Plate spring for slide plate	1	1	
A52	HA124B0711	Slide plate	1	1	
A53	H1100B2060	Needle plate	1	1	
A54	HA300B2190	Screw	2	2	
A55	HA700B2030	Screw	2	2	
A56	H5341B8001	Screw	1	1	SM11/64(40)×26
A57	H6517B8001	Fave plate	1	1	
A58	HB5253B081	Arm		1	
A58	H6507B8001	Arm	1		
A59	HB5254B081	Bed		1	
A59	H6508B8001	Bed	1		
A60	HA100B2100	Three hole thread guide	1		

# B.SEWING MECHANISM

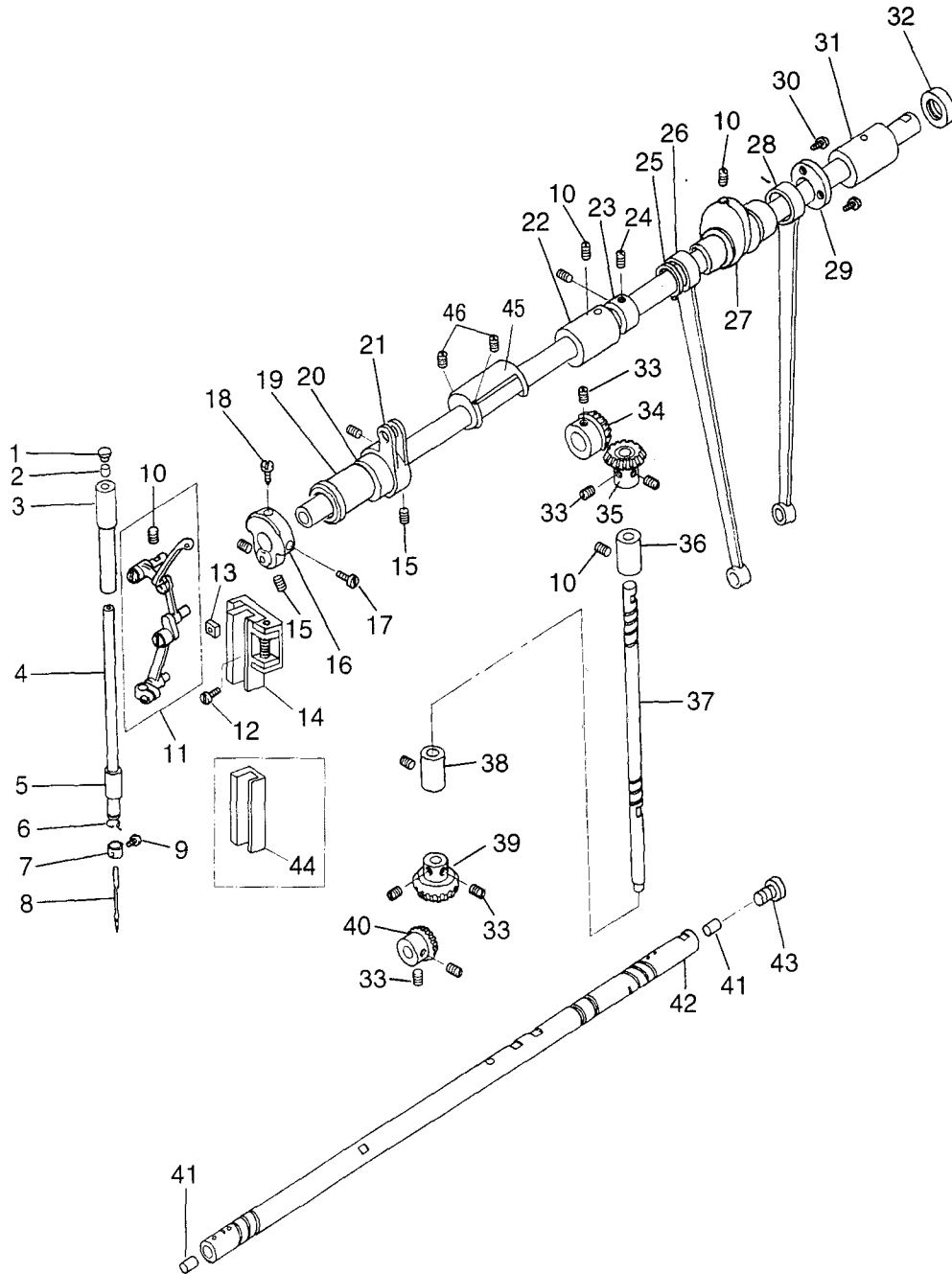

## B.SEWING MECHANISM

Fig. No.	Part No.	Description	1	1 D	Remarks
B01	HA300B2090	Rubber plug	1	1	φ8.8
B02	HA100C2100	Felt plug	1	1	
B03	HA100C2080	Needle bar bushing (upper)	1	1	
B04	H2100C2010	Needle bar	1	1	
B05	HA804B0652	Needle bar bushing (lower)	1	1	
B06	HA500C2060	Lower thread guide	1	1	
B07	HA500C2030	Thread guide	1	1	
B08	H2000G2030	Needle	1	1	DP×17 #22
B09	HA100C2170	Set screw	1	1	SM1/8(44)×4.5
B10	HA100C2020	Screw	6	6	SM15/64(28)×10
B11	H1104C0065	Thread take-up lever assay	1	1	
B12	HA100C2190	Screw	2	2	SM11/64(40)×8
B13	HA100C2200	Slide block	1	1	
B14	HA704G0065	Needle bar connecting link guide		1	
B15	HA307C0662	Set screw	4	4	SM1/4(40)×6
B16	HA307C0661	Needle bar crank	1	1	
B17	HA100C2060	Set screw	1	1	SM9/32(28)×13
B18	HA307C0662	Set screw	1	1	SM9/32(28)×14
B19	HA100D2030	Upper shaft bushing (upper)	1	1	
B20	H6013C8001	Upper feed lifting cam	1	1	
B21	H6016C8001	Upper feed rock crank (left)	1	1	
B22	HA100D2040	Upper shaft bushing (middle)	1	1	
B23	HA108G0661	Collar for upper shaft	1	1	
B24	HA105D0662	Screw	2	2	SM1/4(40)×4
B25	HA112D3012	C-type retaining ring	1	1	
B26	HA112D3013	Crank rock	1	1	
B27	H6510D8001	Feed cam	1	1	
B28	HA7311C506	Feed rock	1	1	
B29	HA7311C206	Feed cam cover	1	1	
B30	HA7311C306	Set screw	3	3	
B31	HA300D2020	Upper shaft bushing (right)	1	1	
B32	HA306D0066	Oil seal	1	1	
B33	HA108C0663	Screw	8	8	SM1/4(40)×7
B34	HA113D2112	Upper shaft gear	1	1	Z=27
B35	HA113D2122	Vertical shaft gear (upper)	1	1	Z=18
B36	HA100D2110	Vertical shaft bushing (upper)	1	1	
B37	H6504D8001	Vertical shaft	1	1	
B38	HA600D2010	Vertical shaft bushing (lower)	1	1	
B39	HA113D2222	Vertical shaft gear (upper)	1	1	Z=28
B40	HA113D2212	Lower shaft gear	1	1	Z=21
B41	HA104D0652	Rubber plug	2	2	(φ7.4×10)
B42	H6506D8001	Arm shaft	1	1	
B43	HA100D2080	Screw	1	1	SM11/32(28)×10

# B.SEWING MECHANISM

Fig. No.	Part No.	Description	1	1 D	Remarks
B44	HA100C2180	Needle bar connecting link guide	1		
B45	H6015C8001	Balance weight	1	1	
B46	HA307C0662	Set Screw	2	2	SM1/4(40)×6

# C. FEEDING AND FEED LIFTING & LOWER SHAFT MECHANISM

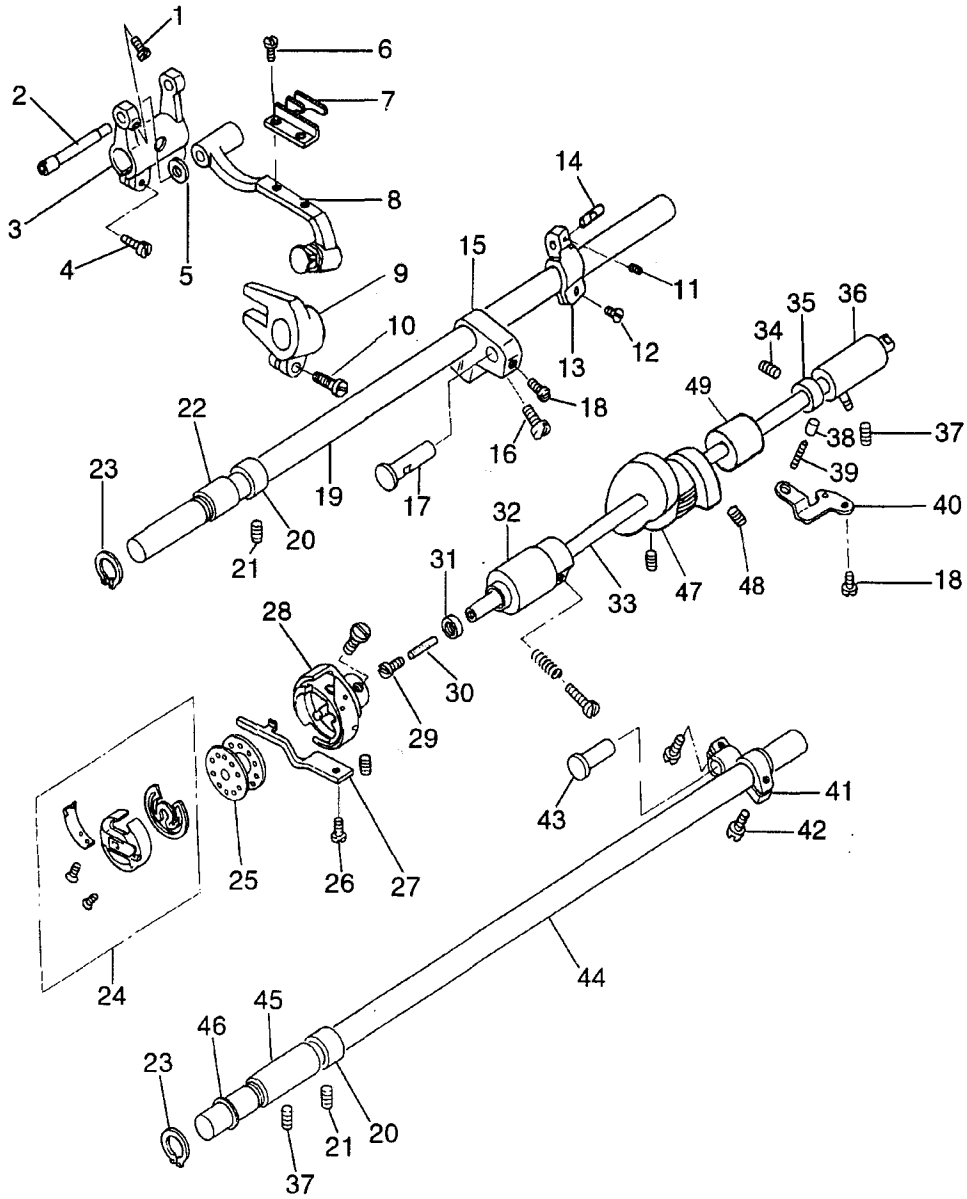

## C.FEEDING AND FEED LIFTING & LOWER SHAFT MECHANISM

Fig. No.	Part No.	Description	1	1 D	Remarks
C01	HA100C2190	Screw	1	1	
C02	HA705J0654	Shaft for feed bar	1	1	
C03	HA104G0011	Feed rock shaft crank	1	1	
C04	HA104G0012	Screw	2	2	
C05	HA104G0656	Washer	1	1	
C06	HA104G0654	Screw	2	2	
C07	H6005D8001	Feed gog	1	1	
C08	H6508G8001	Feed bar assy	1	1	
C09	H1204D0651	Feed lifting rock shaft fork	1	1	
C10	HA111G0683	Screw	1	1	
C11	HA7311C806	Screw	1	1	SM11/64(40)×7
C12	HA7311C606	Screw	1	1	SM11/64(40)×15
C13	HA8211C205	Feed rock shaft crank (right)	1	1	
C14	HA706C11B2	Pin	1	1	
C15	H6504G8001	Feed rock shaft crank	1	1	
C16	HA104G0012	Screw	1	1	SM3/16(28)×12
C17	H6505G8001	Pin	1	1	
C18	HA104F0654	Screw	2	2	
C19	HA300G2050	Feed rock shaft	1	1	
C20	HA108G0661	Collar for feed rock shaft	2	2	
C21	HA105D0662	Screw	4	4	
C22	HA100G2040	Bushing for feed rock shaft	1	1	
C23	H007009150	C-type retaining ring	1	1	GB/T894.1 15
C24	HA900E2030	Bobbin case		1	
C24	HA608E0067	Bobbin case	1		
C25	HA600E2060	Bobbin		1	
C25	H1100E2010	Bobbin	1		
C26	HA100E2150	Screw	1	1	
C27	H2100E2010	Hook positioner	1	1	
C28	HA906E0066	Rotating hook		1	
C28	HA600E2070	Rotating hook	1		
C29	HA1111E104	Screw	1	1	
C30	HA1111E204	Oil felt for hook shaft	1	1	
C31	HA106E0071	Oil seal	1	1	
C32	HA100E2040	Bushing for hook shaft (left)	1	1	
C33	HA604E0651	Hook shaft	1	1	
C34	HA305E0662	Screw	2	2	
C35	HA305E0661	Collar for hook shaft	1	1	
C36	HA311E0671	Bushing for hook shaft (right)	1	1	
C37	HA100C2020	Screw	2	2	
C38	HA300E2100	Plunger	1	1	
C39	HA300E2110	Coil spring	1	1	
C40	HA900M0010	Guide plate		1	

## C.FEEDING AND FEED LIFTING & LOWER SHAFT MECHANISM

Fig. No.	Part No.	Description	 1	 1   D	Remarks
C40	HA600E2020	Guide plate	1		
C41	HA306G0671	Feed lifting rock shaft crank (right)	1	1	
C42	HA104G0012	Screw	2	2	
C43	HA100G2070	Pin	1	1	
C44	HA704K0652	Feed lifting rock shaft	1	1	
C45	HA100G2120	Bushing for feed lifting shaft	1	1	
C46	HA100G2130	Washer	1	1	
C47	HA710E0691	Thread trimmer cam		1	
C48	HA710E0692	Screw		2	
C49	HA704B0653	Bushing for hook shaft (middle)		1	



# D. STITCH REGULATOR MECHANISM

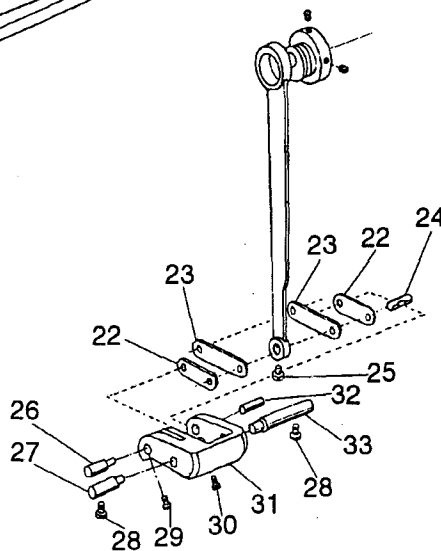
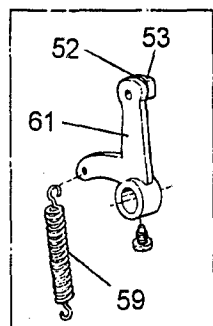
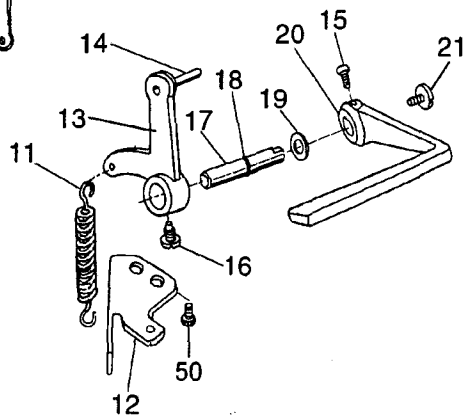
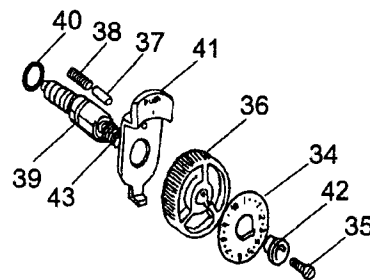
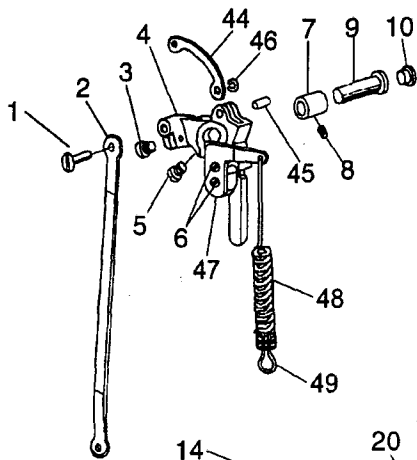
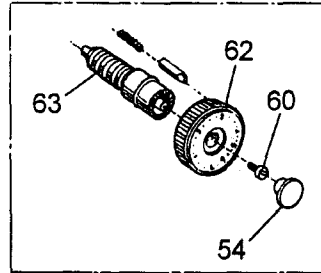
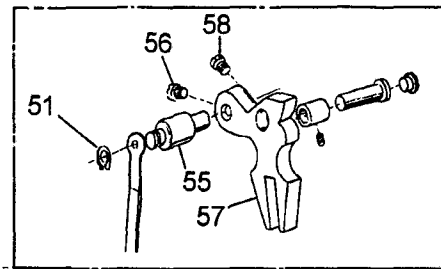

## D.STITCH REGULATOR MECHANISM

Fig. No.	Part No.	Description	1	1 D	Remarks
D01	HA700C2060	Pin		1	
D02	HA7311C406	Connecting rod stud	1	1	
D03	HA111G0683	Screw		1	
D04	HB5251F081	Feed regulator		1	
D05	HA113F0684	Screw		1	SM15/64(28)×10
D06	HA100C2190	Screw		2	
D07	HA704B0655	Bushing for feed regulator	1	1	
D08	HA100C2020	Screw	1	1	SM15/64(28)×10
D09	HA100F2040	Pin	1	1	
D10	HA700B2120	Rnubber plug	1	1	(φ20×6 )
D11	H2600E2050	Spring		1	
D12	HA800F2010	Spring holder		1	
D13	H2605E0661	Crank		1	
D14	H2207D0671	Slide block pin		1	
D15	04F0654	Screw	1	2	SM15/64(28)×10
D16	HA100F2130	Screw	1	1	SM15/64(28)×14
D17	HA113F3021	Feed reversing lever shaft	1	1	
D18	HA113F3022	O-ring	1	1	9×1.9
D19	HA100F2110	Spring washer	1	1	
D20	HA309F0671	Feed reversing lever	1	1	
D21	HA113F0683	Screw	1	1	SM3/16(28)×6.5
D22	HA706C1191	link (short)	2	2	
D23	HA8211C305	Link (long)	2	2	
D24	HA706C11B1	Link stud	1	1	
D25	HA7311C806	Screw	1	1	
D26	HA7311CF06	Link stud	1	1	
D27	HA700C2050	Feed regulator shaft (left)	1	1	
D28	HA111G0683	Screw	2	2	
D29	HA7311CC06	Screw	1	1	
D30	HA7311CD06	Screw	1	1	
D31	HA7311CG06	Stitch length adjusting crank	1	1	
D32	HA7311CE06	Link stud	1	1	
D33	HA700C2040	Feed regulator shaft (right)	1	1	
D34	HB5253F081	Plate for stitch length		1	
D35	HA720F0686	Screw		1	SM3/16(28)×18
D36	HA7421F120	Dial		1	
D37	HA100F2080	Stopper pin	1	1	
D38	HA100F2090	Spring for stopper pin	1	1	
D39	HA720F0681	Screw bar		1	
D40	HA109F0674	O-ring	1	1	14×2.4
D41	HA720F0683	Stopper pin releasing lever		1	
D42	HA720F0685	Bushing		1	
D43	HA720F0687	Coil spring		1	

## D.STITCH REGULATOR MECHANISM

Fig. No.	Part No.	Description	 1	 1   D	Remarks
D44	HB5255F081	Link for resrve feed		1	
D45	H2204D0652	Pin		1	
D46	H007013040	E-type ring		1	GB/T896 4
D47	H2600E2020	Spring retainer		1	
D48	HA806C0674	Coil spring		1	
D49	HA806C0675	Spring holder		1	
D50	HA800F2020	Screw		1	
D51	H007013050	E-type ring	1		GB/T896 5
D52	HA1511F115	Slide block pin	1		
D53	HA1511F215	Slide block	1		
D54	HA300F2050	Rubber piug	1		
D55	H1204E0652	Stitch length adjusting swing shaft	1		
D56	HA100C2190	Screw	1		
D57	H1404E0651	Feed regulator	1		
D58	HA104F0654	Screw	4		
D59	HA115F0692	Spring	1		
D60	HA109F0673	Screw	1		
D61	HA115F0691	Crank	1		
D62	H3100E2070	Dial	1		
D63	HA506F0671	Screw bar	1		

# E. PRESSER FOOT MECHANISM

---

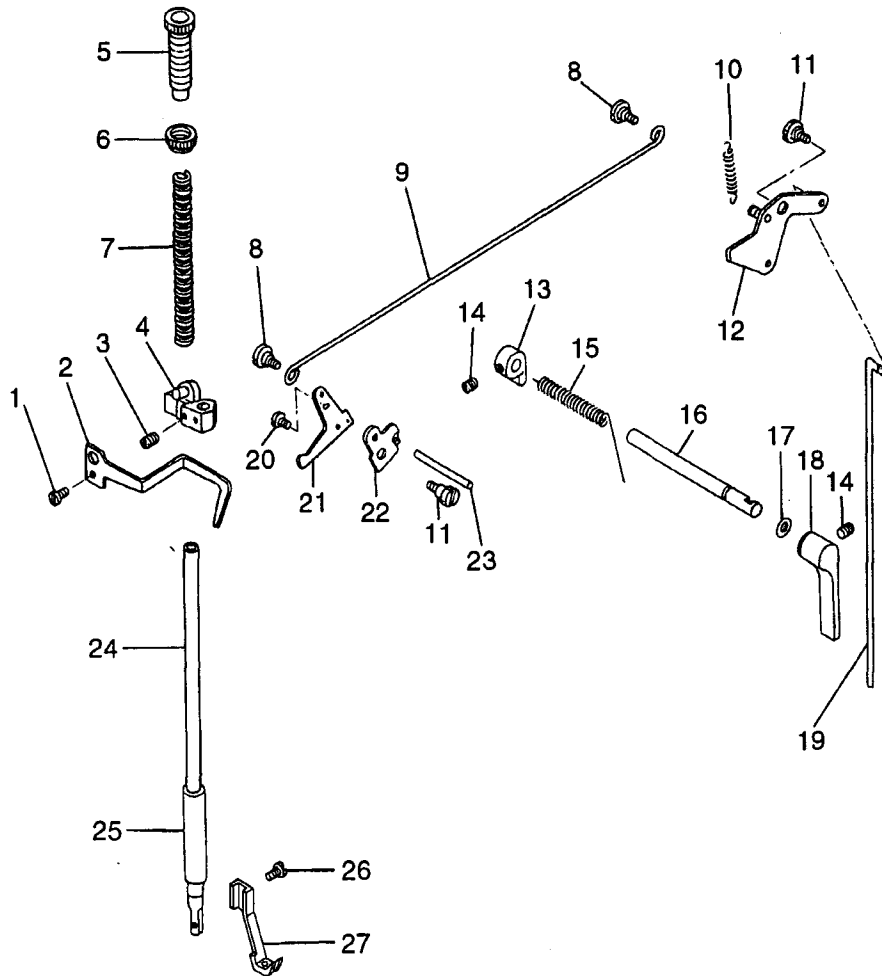

## E.PRESSER FOOT MECHANISM

Fig. No.	Part No.	Description	1	1 D	Remarks
E01	HA300B2130	Screw	1	1	SM11/64(40)×5.5
E02	HA300H2120	Thread guide	1	1	
E03	HA3411D308	Presser bar guide bracket	1	1	SM15/64(28)×7
E04	H2305H0671	Screw	1	1	
E05	H2005I0065	Thumb screw	1	1	
E06	HA117H0692	Nut	1	1	
E07	H1100H2020	Presser bar spring	1	1	
E08	HA107H0662	Screw	2	2	SM3/16(28)×3.5
E09	HA107H0663	Knee lifter lever	1	1	
E10	H6017H8001	Spring	1	1	
E11	HA100H2050	Stud bolt	2	2	SM15/64(28)×10
E12	H6016H8001	Knee lifter lever	1	1	
E13	H6010H8001	Presser bar lifting cam	1	1	
E14	HA100C2090	Screw	2	2	
E15	H6008H8001	Spring	1	1	
E16	H6509H8001	Presser bar lifting shaft	1	1	
E17	HA300H2080	O-ring	1	1	
E18	H6006H8001	Presser bar lifter	1	1	
E19	HA306H0671	Knee lifter connecting rod	1	1	
E20	HA107H1013	Spring	1	1	SM11/64(40)×6.5
E21	HA107H1011	Knee lifter lever (left)	1	1	
E22	HA305H6611	Tension releasing cam	1	1	
E23	HA100H2060	Thread releasing pin	1	1	
E24	H2000I2010	Presser bar	1	1	
E25	HA300H2090	Bushing for presser bar	1	1	
E26	HA100H2150	Screw	1	1	SM9/64(40)×11
E27	H2205F0651	Presser foot	1	1	

F. TOP FEED MECHANISM

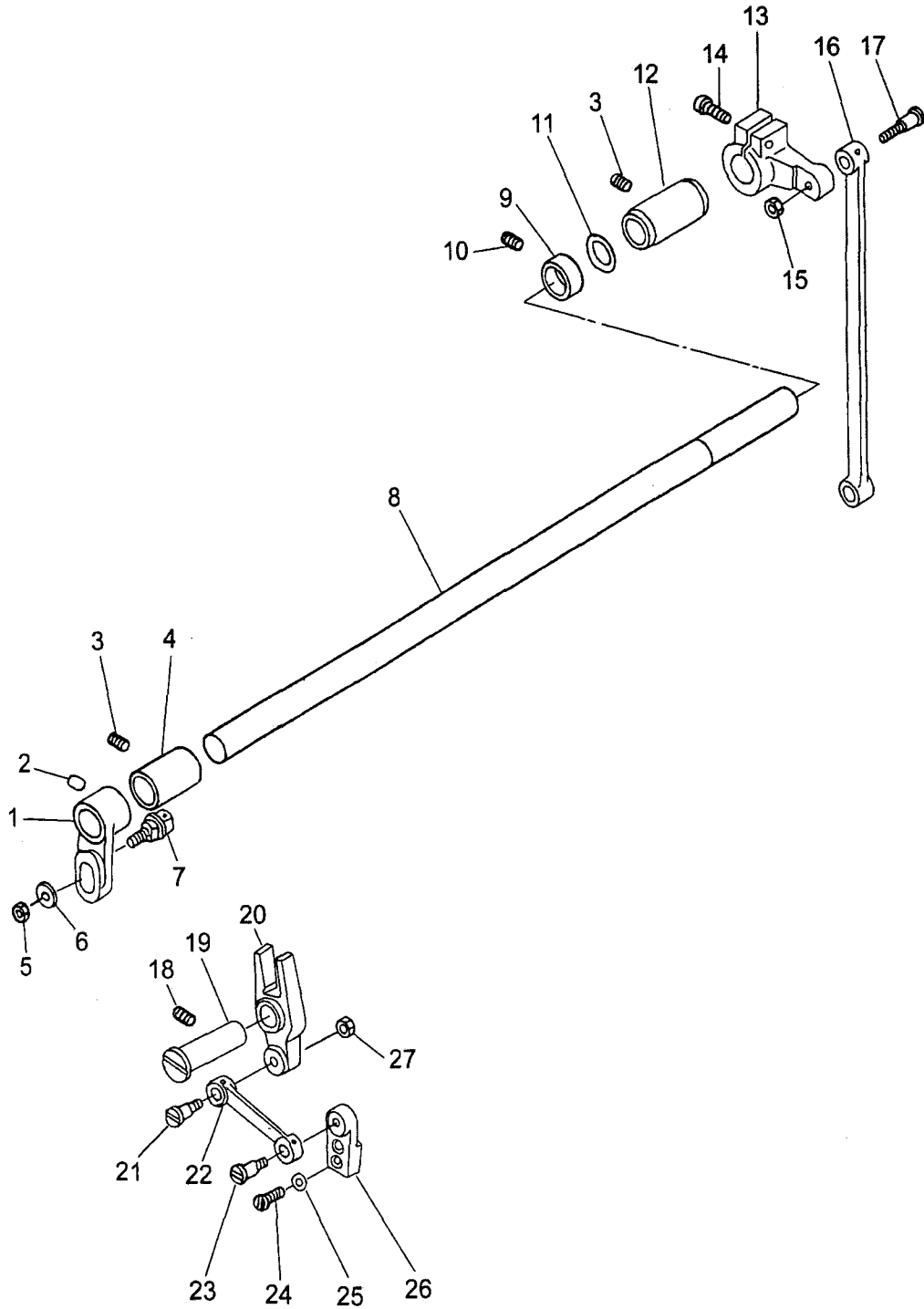

## F.TOP FEED MECHANISM

Fig. No.	Part No.	Description	1	1 D	Remarks
F01	H2009N0065	Upper feed rock shaft crank (left)	1	1	
F02	H602040240	Pin	1	1	GB/T117 A4×24
F03	HA100B2110	Screw	2	2	
F04	H2100I2060	Bushing for upper feed rock shaft crank	2	2	
F05	H2013N0067	Nut	1	1	
F06	H2013J0065	Washer	1	1	
F07	H2121I0065	Feed connecting slick block	1	1	
F08	H2009N0066	Upper feed rock shaft	1	1	
F09	HA108G0661	Collar	1	1	
F10	HA105D0662	Screw	2	2	
F11	H6018F8001	O-ring	1	1	
F12	H6505I8001	Bushing for upper feed rock shaft crank	1	1	
F13	H6506I8001	Upper feed rock shaft crank (right)	1	1	
F14	H6017F8001	Screw	1	1	SM15/64(28)×18
F15	H2010J0066	Nut	1	1	
F16	H6505I8001	Feed driver connecting rod	1	1	
F17	H2012N0066	Screw	1	1	
F18	H2100I2070	Screw	1	1	
F19	H2013N0066	Hinge pin	1	1	
F20	H2013N0069	Feed connecting lever	1	1	
F21	H2008N0065	Screw	1	1	
F22	H2013N0070	Walking foot connecting rod	1	1	
F23	H2004J0662	Screw	1	1	SM1/4(40)×5
F24	H2004J0067	Screw	2	2	
F25	HA100I2050	Spring washer	2	2	
F26	H2004J0661	Feed arm	1	1	
F27	H2008N0066	Nut	1	1	

# G. TOP FEED MECHANISM

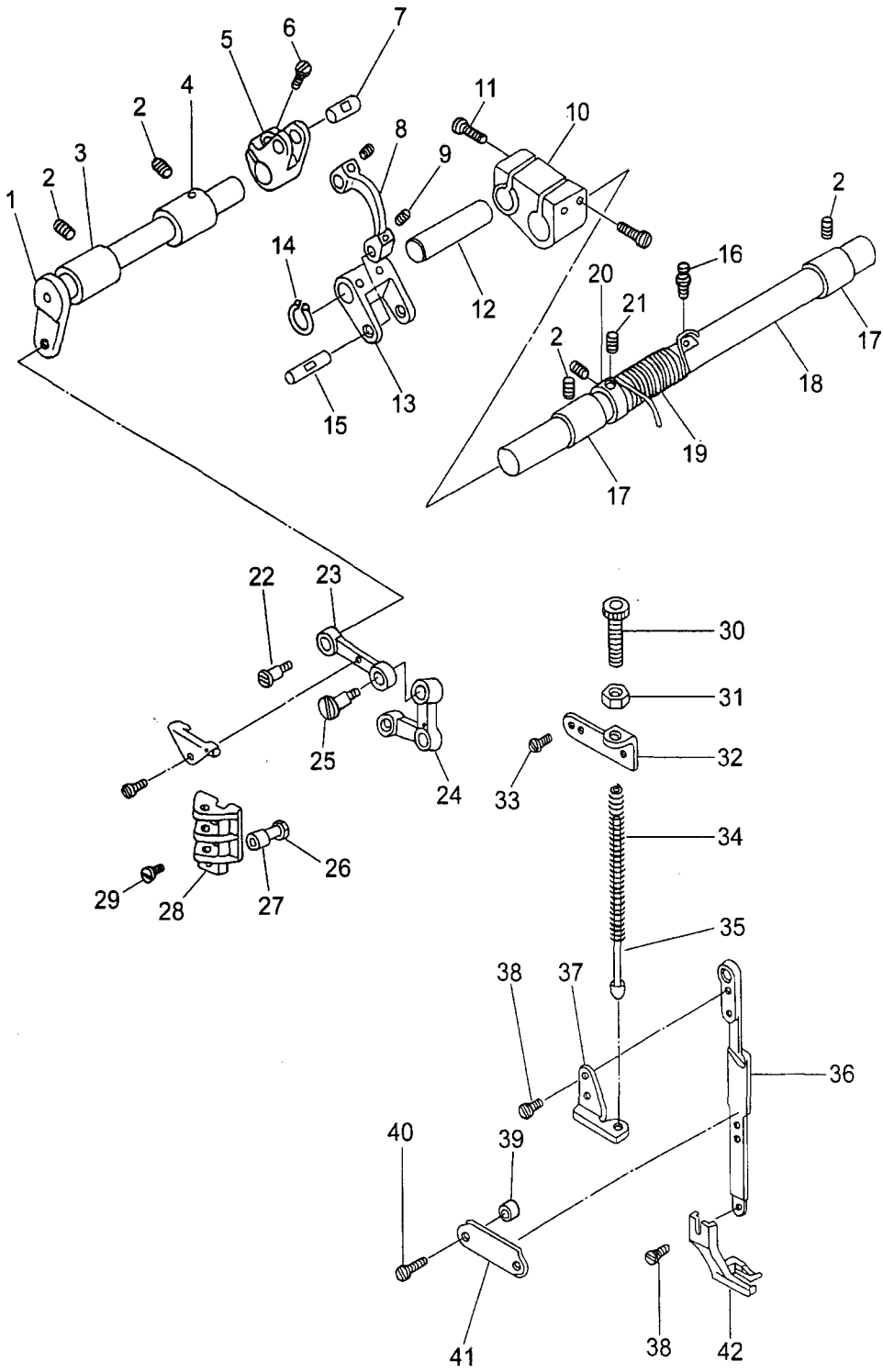



## G.UPPER FEED LIFTING ROCK SHAFT MECHANISM

Fig. No.	Part No.	Description	1	1 D	Remarks
G01	H6005G8001	Upper feed lifting rock shaft	1	1	
G02	HA100B2110	Screw	4	4	SM11/64(40)×5.5
G03	H6006G8001	Bushing for upper feed lifting rock shaft	1	1	
G04	H6007G8001	Bushing for upper feed lifting rock shaft	1	1	
G05	H6009G8001	Upper feed lifting rock crank	1	1	
G06	HA800F2020	Screw	1	1	SM15/64(28)×13.5
G07	H6010G8001	Upper feed lifting rock crank shaft	1	1	
G08	H6011G8001	Link	1	1	
G09	H6039G8001	Screw	2	2	SM11/64(40)×3.8
G10	H6013G8001	Upper feed regulator bracket	1	1	
G11	HA7311C606	Screw	4	4	SM11/64(40)×15
G12	H6014G8001	Shaft for upper feed lifting rock shaft	1	1	
G13	H6015G8001	Crank for upper feed lifting rock crank	1	1	
G14	H007009100	C-type ring	1	1	GB/T894.1 10
G15	H6016G8001	Pin	1	1	
G16	H6020G8001	Cam follower	1	1	SM15/64(28)×10
G17	HA100G2040	Bushing for upper feed shaft	2	2	
G18	H6504I8001	Upper feed regulator shaft	1	1	
G19	H6021G8001	Spring	1	1	
G20	HA108G0661	Collar	1	1	
G21	HA105D0662	Screw	2	2	SM1/4(40)×4
G22	H2004J0662	Screw	2	2	SM1/4(40)×5
G23	H6023G8001	Link for feed lifting rock shaft	1	1	
G24	H2100I2020	Bell crack	1	1	
G25	H2004J0653	Screw	1	1	
G26	H2004J0655	Feed crank guide shaft	1	1	
G27	H2000J2030	Lifting presser spring guide pin	1	1	
G28	H2000J2020	Lifting presser plate	1	1	
G29	H2000I2050	Screw	2	2	
G30	H2010J0065	Screw	1	1	
G31	H2010J0066	Nut	1	1	
G32	H6032G8001	Presser regulating bracket	1	1	
G33	HA300C2030	Screw	2	2	
G34	H6038G8001	Spring	1	1	
G35	H2000J2040	Spring guide bar assay	1	1	
G36	H2004J0654	Walking foot guide link	1	1	
G37	H6033G8001	Spring guide bar holder	1	1	
G38	HA100H2150	Screw	3	3	
G39	H2000N0040	Washer	2	2	
G40	HA111G0683	Screw	2	2	
G41	H2000N0030	Walking foot guide barcket	1	1	
G42	H2000N0010	Walking foot	1	1	

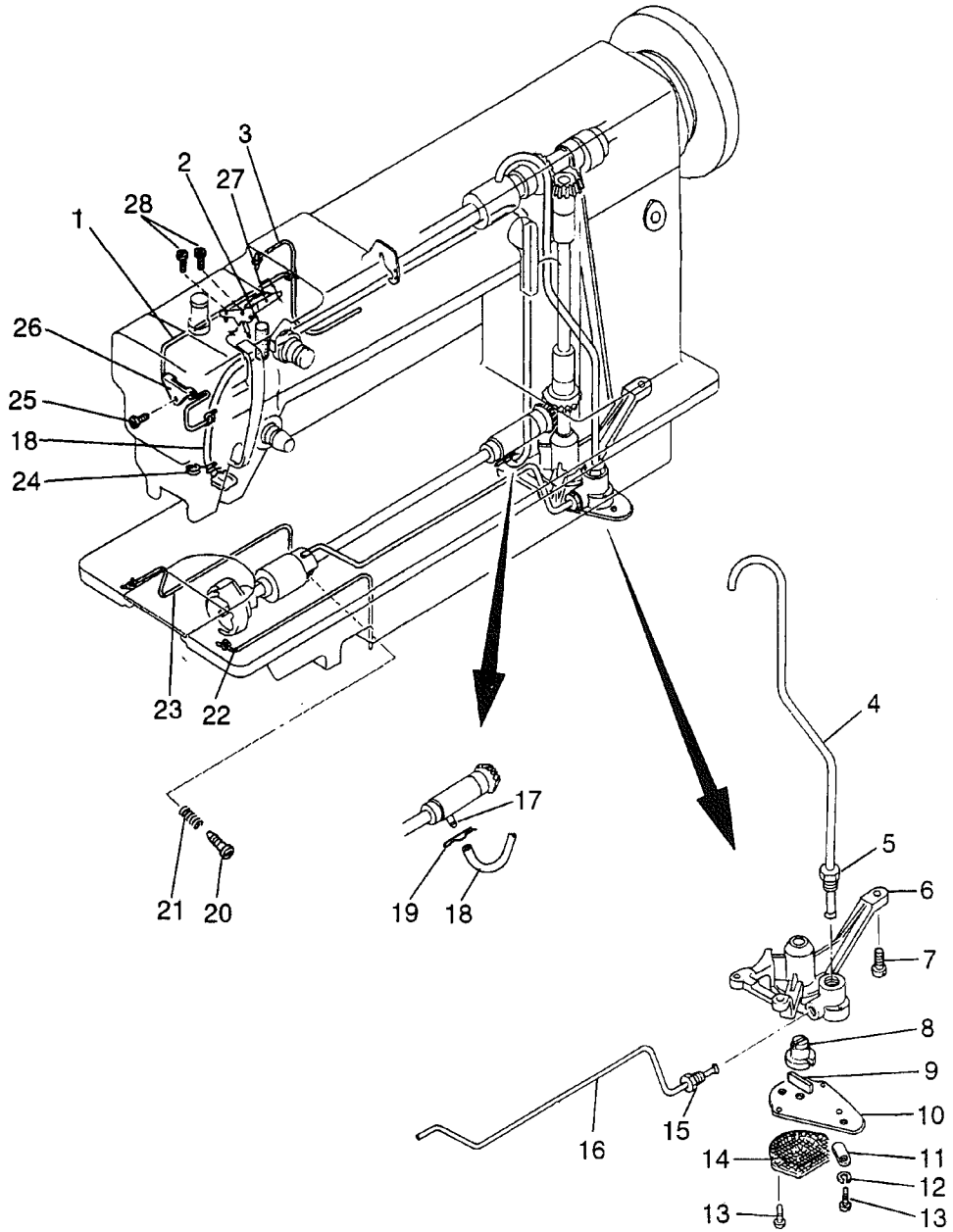

# H.OIL LUBRICATION MECHANISM

Fig. No.	Part No.	Description	1	1 D	Remarks
H01	H6017G8001	Oil wick	1	1	
H02	HA700B2150	Oil felt	1	1	
H03	H6019I8001	Oil wick	1	1	
H04	HA116I0681	Upper shaft oil tube	1	1	
H05	HA116I0682	Bushig	1	1	
H06	H6006I8001	Oil pump	1	1	
H07	HA100I2090	Screw	3	3	
H08	H6010I8001	Rooter	1	1	
H09	H6011I8001	slider	1	1	
H10	H6012I8001	Oil pump cover		1	
H10	H6507J8001	Oil pump cover	1		
H11	HA100I2070	Oil adjusting plate	1	1	
H12	HA100I2050	Spring washer	1	1	3.5
H13	HA100I2040	Screw	3	3	
H14	HA111I0065	Oil pump filter	1	1	
H15	HA113I0661	Bushing	1	1	
H16	HA113I0662	Lower shaft oil tube	1	1	
H17	HA110E0672	Oil pipe for lower shaft bushing	1	1	
H18	HA305I0661	Oil return tube	1	1	3×650
H19	HA300I2030	Oil return tube cilp	1	1	
H20	HA100E2050	Oil adjusting screw	1	1	
H21	HA100E2060	Oil adjusting spring	1	1	
H22	HA305G0664	Oil wick	1	1	
H23	HA304G0655	Oil wick	1	1	
H24	HA300I2060	Oil felt holder	1	1	
H25	HA106B0676	Screw	1	1	
H26	H6009I8001	Oil wick holder	1	1	
H27	H3004L0065	Oil wick holder	1	1	
H28	H2200H2150	Screw	2	2	

# I. UPPER FEED ROCK SHAFT MECHANISM

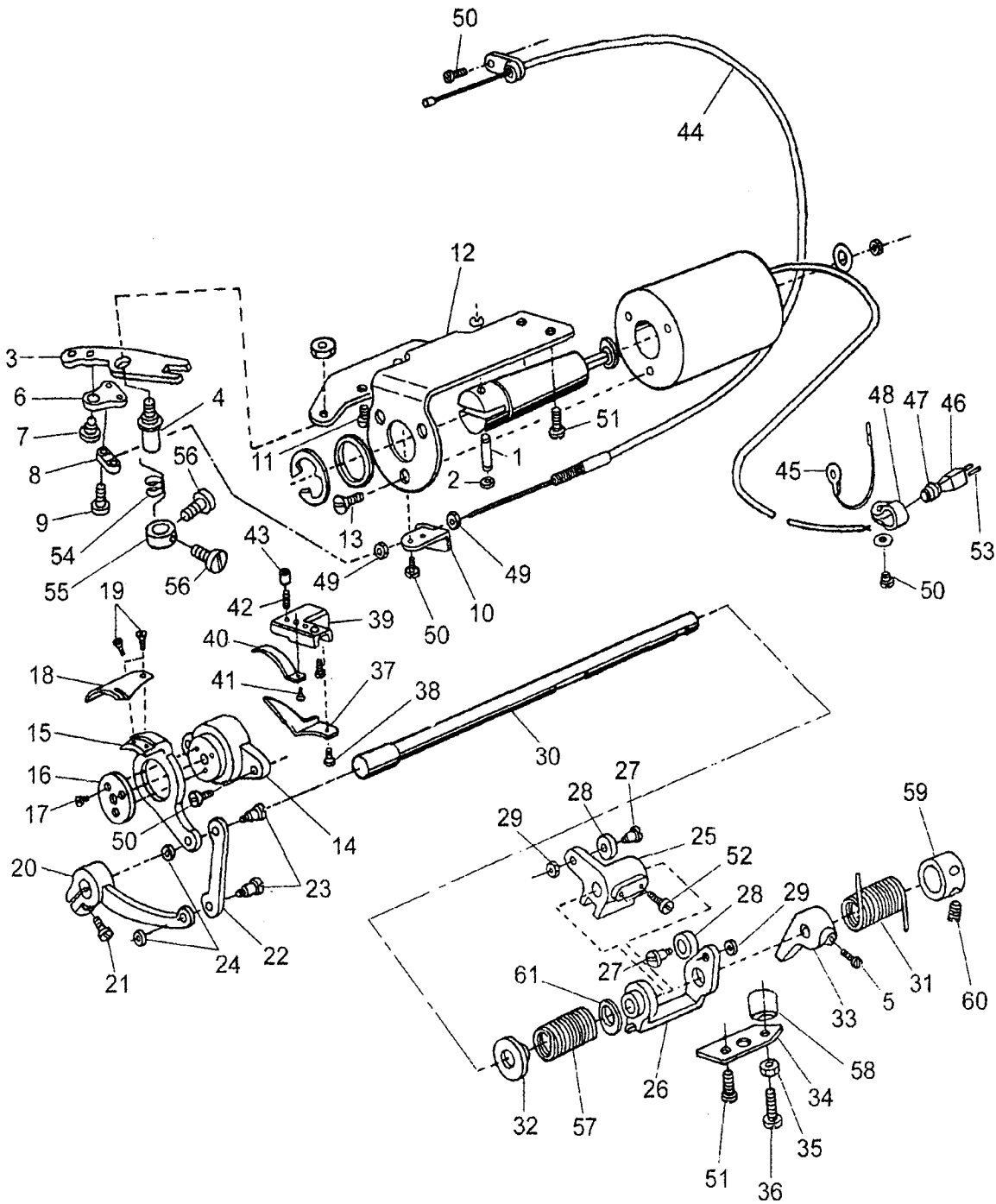

# I.UPPER FEED ROCK SHAFT MECHANISM

Fig. No.	Part No.	Description	1	1 D	Remarks
I01	HA712N0692	Link stud		1	
I02	H007013040	E-type ring 4		2	GB/T896 4
I03	HA712N0698	Thread trimmer driving lever		1	
I04	HA712N0695	Stud screw		1	SM3/16(28)×6
I05	HA113F0684	Set screw		1	
I06	HA712N6910	Flexible wire bracket		1	
I07	HA712N0699	Set screw		1	SM11/64(40)×4
I08	HA712N6911	Link bracket		1	
I09	HA712N6912	Set screw		2	SM1/8(44)×7
I10	HA712N6913	Holder		1	
I11	HA100E2150	Set screw		1	
I12	HA7511N212	Solenoid bracket		1	
I13		P-type screw		3	
I14	HA704N1111	Knife holding bracket saddle		1	
I15	HA904N1111	Knife holding bracket saddle (left)		1	
I16	HA704N1113	Washer		1	
I17	HA704N1114	Set screw		3	
I18	HA9111N204	Movable knife (left)		1	
I19	HA7111N704	Set screw		2	
I20	HA7111N604	Knife driving crank		1	
I21	HA719B7011	Set screw		1	
I22	HA7111N404	Link		1	
I23	HA7111N204	Set screw		2	
I24	HA7111N304	Nut		2	
I25	HA7211N106	Cam follower crank 1		1	
I26	HA7211N206	Cam follower crank 2		1	
I27	HA7221N206	Roller stud		2	
I28	HA7221N106	Roller		2	
I29	HA706N0663	Nut		2	
I30	HA900N0020	Knife driving shaft		1	
I31	HA700N0110	Coil spring		1	
I32	HA700N0050	Brshing		1	
I33	HA906N0661	Stopper lever		1	
I34	HA710N0682	Lever stopper plate		1	
I35	HA710N0683	Nut		1	SM15/64(28)×23
I36	HA7411N110	Set screw		1	
I37	HA9121N204	Thread finger		1	
I38	HA7311CH06	Set screw		3	
I39	HA7121N104	Bracket for fixed blade		1	
I40	HA9121N104	Fixed blade		1	
I41	HA7121N304	Set screw		1	
I42	HA7121N604	Set screw		1	
I43	HA7121N704	Nut		1	

# I. UPPER FEED ROCK SHAFT MECHANISM

Fig. No.	Part No.	Description	1	1 D	Remarks
I44	HA713N0702	Flexible wire		1	
I45	HA705Q0065	Grounded wire		1	
I46	HA700Q0010	Connector plug		1	
I47	HA704O0657	Gasket		1	
I48	HA708P0668	Cord holder HP-3N		1	
I49	H003002050	Nut M5		2	GB/T6170 M5
I50	HA300B2170	Set screw		5	
I51	HA700N0080	Set screw		4	SM15/64(28)×12
I52	HA113F0684	Set screw		2	
I53	HA7641B319	Adaptor		1	
I54	HA712N0697	Spring for thread trimmer driving lever		1	
I55	HA712N0696	Collar for thread trimmer driving lever		1	
I56	HA7311CC06	Set screw		2	
I57	HA700N0040	Coil spring		1	
I58	HA7411N210	Dead block		1	
I59	HA715N0711	Collar with screw		1	
I60	HA105D0662	Set screw		1	
I61	HA706N0664	Washer		1	

# J. TOUCH BACK MECHANISM & DETECTOR MECHANISM

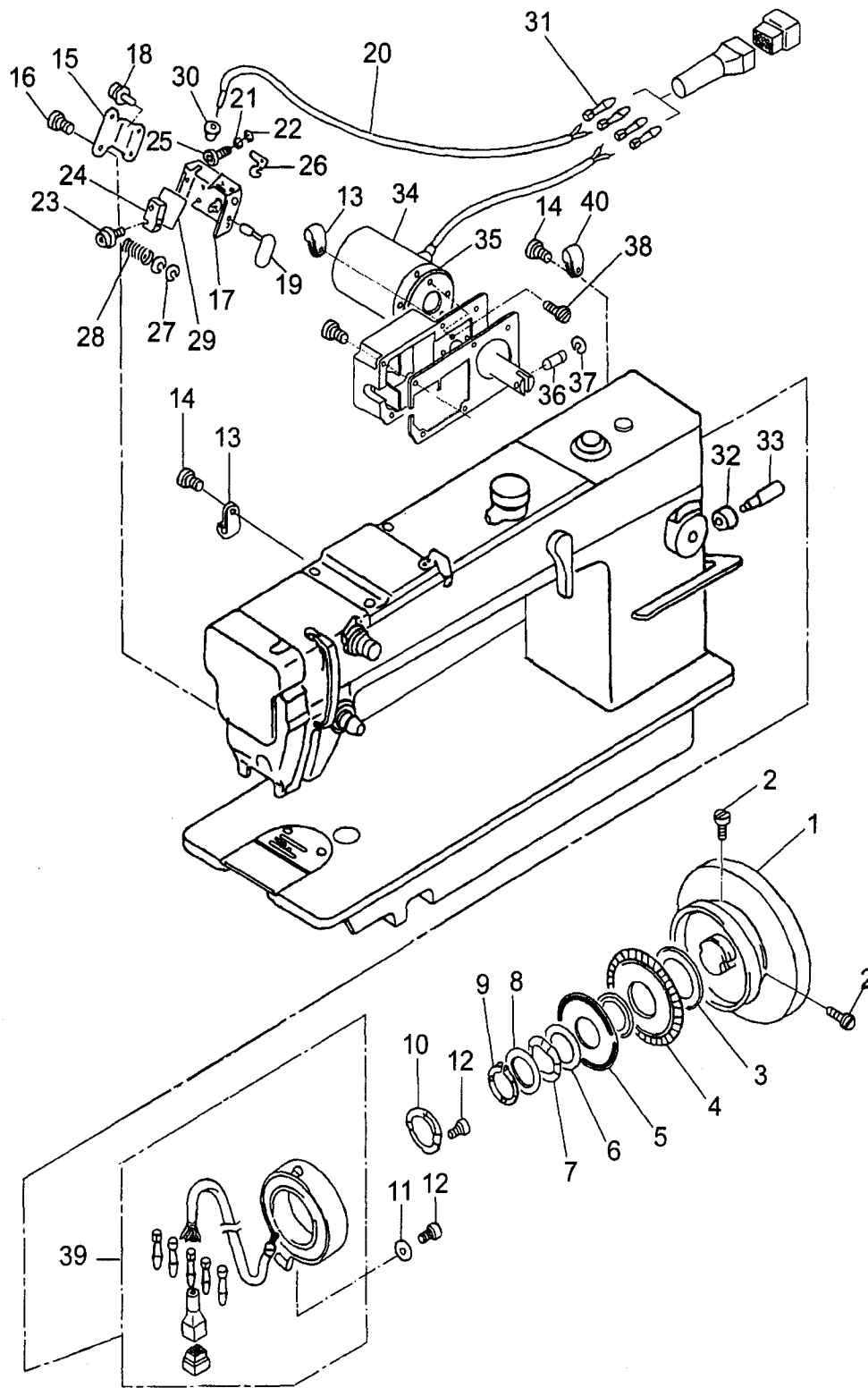

## J.TOUCH BACK MECHANISM & DETECTOR MECHANISM

Fig. No.	Part No.	Description	1	1 D	Remarks
J01	H2204I0651	Pulley		1	
J01	H2000C2040	Pulley	1		
J02	HA110D0672	Screw	2	2	
J03	HA700R0030	Spacer 1		2	
J04	HA700R0010	Speed command disc 1		1	
J05	HA700R0020	Speed command disc 2		1	
J06	HA700R0040	Spacer 2		1	
J07	HA700R0050	Supporter spring		1	
J08	HA700R0060	Washer		1	
J09	H007009300	C-type ring		1	GB/T894.1 30
J10	HA703R0066	Detector bracket assay		1	
J11	HA703R0067	Washer		1	
J12	HA300C2030	Screw		3	
J13	HA708P0668	Cord holder		2	
J14	HA300B2170	Screw		2	
J15	H6005K8001	Bracket		1	
J16	HA300B2160	Screw		2	SM11/64(40)×10
J17	H2205I0661	Bracket for touch switch		1	
J18	HA7221P508	Screw		2	
J19	HA704O0021	Push button		1	
J20	HA7161O104	Vinyl cap-trire cable for touch switch		1	
J21	HA704O6512	Washer		2	
J22	HA704O6511	Washer		2	
J23	HA704O6510	Screw		2	
J24	HA704O0655	Micro switch		1	
J25	HA704O0659	Screw		2	
J26	HA704O0654	Spring plate		1	
J27	H007013030	E-type ring		2	GB/T896 3
J28	HA704O0653	Spring		1	
J29	HA704O0658	Insulator set		1	
J30	HA704O0657	Rubber plug		1	
J31	HA7641B319	Terminal pin		2	
J32	H2204G0652	Rubber plug		1	
J33	H2204G0651	Screw		1	
J34	H2206I0673	Solenoid assay for touch black		1	
J35	HB5256F081	Washer		1	
J36	HA712N0692	Pin		1	
J37	H007013040	E-type ring		1	GB/T896 4
J38	HA300C2030	Screw		4	
J39	HA700R0000	Detector bracket assay		1	
J40	HA700Q0050	Cord holder		1	



# K. ACCESSORIES

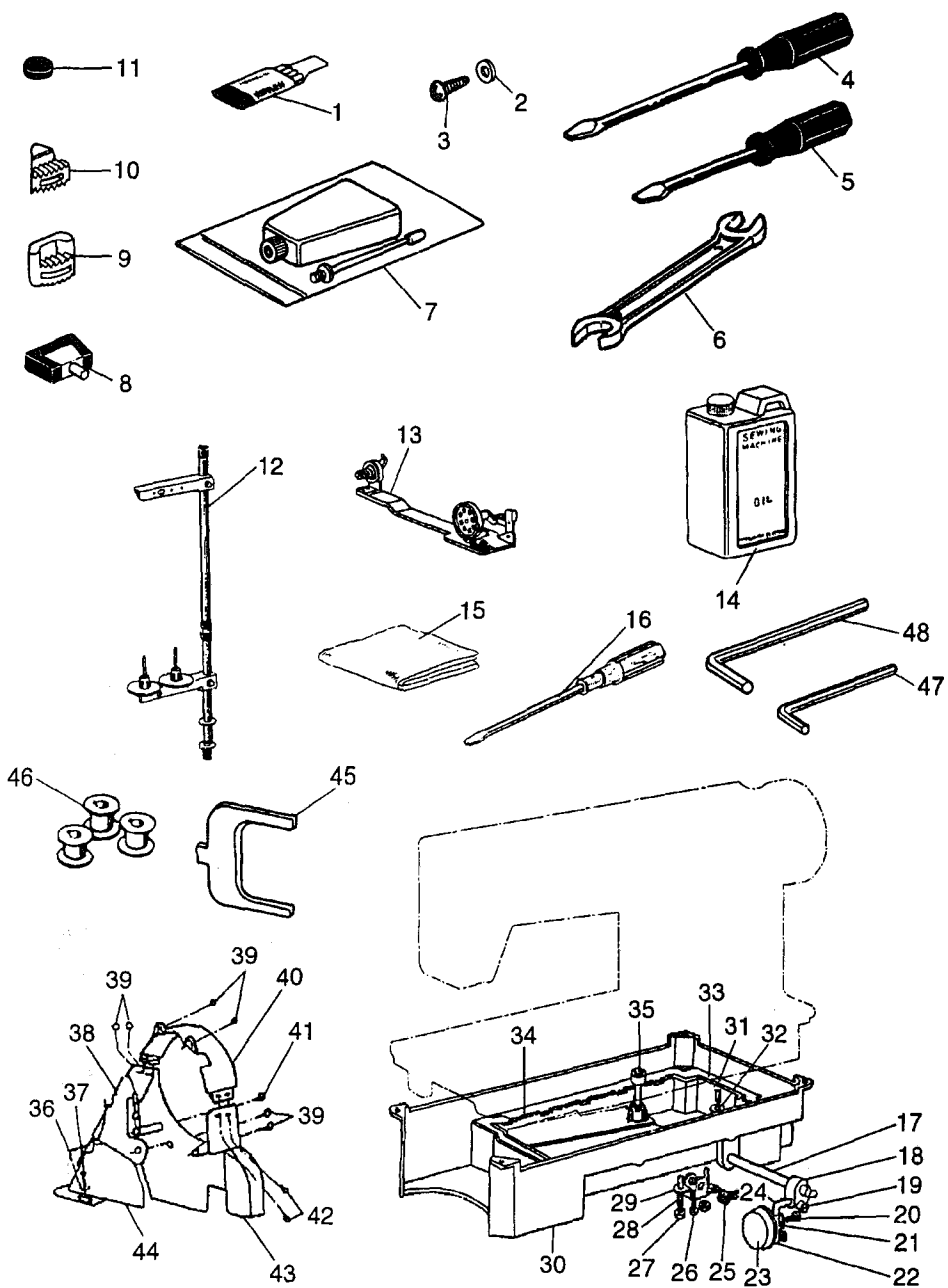

## K.ACCESSORIES

Fig. No.	Part No.	Description	1	1 D	Remarks
K01		Needle	4	4	DP×17 #22
K02	HA300J2230	Washer	2	2	5
K03	H801045200	Screw	2	2	GB/T99 4.5×20
K04	HA300J2200	Screw driver (middle)	1	1	
K05	HA300J2210	Screw driver (small)	1	1	
K06	HA300J2220	Spanner	1	1	
K07	HA100J2110	Oil with oiler	2	1	
K08	HA110J0701	Hinge with rubber cushion	2	2	
K09	HA300J2050	Vibration preventing rubber (large)	2	2	
K10	HA300J2060	Vibration preventing rubber (small)	2	2	
K11	HA100J2120	Magnet block	1	1	
K12	HA200J2030	Thread stand assy	1	1	
K13	HA905S0066	Bobbin winder assy	1	1	
K14	HA100J2170	Oil tank	1	1	
K15	HA100J2180	Cover	1	1	
K16	HA300J2070	Screw driver (large)	1	1	
K17	HA300J2160	Knee lifter shaft	1	1	
K18	HA106J0663	Knee lifter driving crank	1	1	
K19	HA300J2180	Screw	2	2	
K20	HA106J0667	Screw	1	1	
K21	HA106J0666	Knee lifter plate stopper	1	1	
K22	HA106J0665	Knee lifter plate	1	1	
K23	HA106J0668	Knee lifter cover	1	1	
K24	HA106J0662	Knee lifter shaft	1	1	
K25	HA104J0657	Coil spring	1	1	
K26	HA110D0672	Screw	1	1	
K27	HA104J6510	Nut	2	2	
K28	HA104J0659	Screw	1	2	
K29	HA104J0658	Knee lifter	1	1	
K30	HA304J0651	Oil reservoir	1	1	
K31	HA104J0652	Screw	1	1	
K32	HA104J0653	Washer	1	1	
K33	HA104J0654	Gasket for oil reservoir (small)	1	1	
K34	HA104J0655	Gasket for oil reservoir (big)	1	1	
K35	HA106J0661	Knee lifter lifting rod	1	1	
K36	HA300J2230	Washer	2	2	5
K37	H801045200	Screw	2	2	GB/T99 4.5×20
K38	H2008O0701	Belt cover	1	1	
K39	HA300B2170	Screw	6	6	SM11/64(40)×8
K40	H2008O0671		1	1	
K41	HA300J2250	Screw	1	1	M4×12.5
K42	HA300J2280	Screw	2	2	SM15/64(28)×8
K43	H2008O0067	Belt cover	1	1	

# K.ACCESSORIES

Fig. No.	Part No.	Description	 1	 1   D	Remarks
K44	HA305J0665	Belt cover	1	1	
K45	HA704S0654	Detector adjusting plate		1	
K46	HA600E2060	Bobbin case		3	
K46	H1100E2010	Bobbin case	3		
K47	HB00001020	Hexdgon socket screw key 2mm		1	GB/T5356 2
K48	HB00001030	Hexdgon socket screw key 3mm		1	GB/T5356 3

**SHANGHAI HUIGONG NO.3 SEWING MACHINE FACTORY**

**ADD: 1418, Yishan Road, Shanghai, China**

**Zip Code: 201103**

**Overseas Business: TEL: 86-21-64853303 FAX: 86-21-64854304**

**E-mail: [highlead@online.sh.cn](mailto:highlead@online.sh.cn) <http://www.highlead.com.cn>**

**The description covered in this manual is subject to change for improvement of the commodity without notice**

**2004.2. Printed**